



AFCAT 1 2025

MAHA MARATHON #1



COMPLETE REVISION

19 FEB 2025
12 PM TO 04 PM



LIVE CLASS



AFCAT 1 2025

MAHA MARATHON

19 TO 21 FEB 2025

12 PM TO 01 PM

MATHS - NAVJYOTI SIR

01 PM TO 02 PM

ENGLISH - ANURADHA MA'AM

02 PM TO 03 PM

REASONING - RUBY MA'AM

03 PM TO 04 PM

STATIC GK - DIVYANSHU SIR

CALL US: 080-69185400

GET IT ON
Google Play

DOWNLOAD
THE APP NOW







AFCAT Exam Online Coaching 2025

AFCAT 2025: 📺 Live Classes ▶ In-Depth Lectures 📖 Study Notes 🚩 Mock Tests 📅 Current Affairs ✂ Defence Current Affairs.

★★★★★ 5.0 (147)

Content 22

Search in bundle 🔍 FILTER BY TYPE ▾

-  **AFCAT 1 2025 Live Batch - 2**
Course • 331 Lessons
-  **AFCAT 2 2024 Exam Answerkey | 09 - 11 Aug 2024 | Shift 1 & 2**
Course • 228 Lessons 1 Trial
-  **AFCAT 1 2024 Live Batch - 2**
Course • 148 Lessons 2 Trials
-  **AFCAT 1 2024 Live Batch - 1**
Course • 315 Lessons 1 Trial
-  **AFCAT Exam Overview**
Course • 26 Lessons



AFCAT
Air Force Common Admission Test

- 📺 Live Classes
- 🎓 In-Depth Lectures
- 📖 Study Notes
- 🚩 Mock Tests
- 📅 Current Affairs
- ✂ Defence Current Affairs

USE CODE: **"WARRIOR10"**
FOR 10% OFF ON THIS COURSE

🕒 180 Days validity

₹ 4,999 ~~₹ 5,999~~ 17% OFF

[BUY BUNDLE](#)

[START A FREE TRIAL](#)

What's included

📁 22 Courses

Other Pricing Plans

Validity 12 Months

365 Days Validity

[Details](#)

₹5,999 ~~₹7,999~~ 25% off

[BUY NOW](#)



Sainik School Exam Course for Class 6

5 Courses

₹ 2,999 ~~₹ 5,999~~

50% OFF



SSB Interview Online Coaching 2025

18 Courses

₹ 6,999 ~~₹ 9,999~~

30% OFF

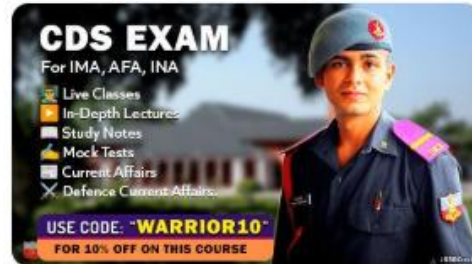

CDS Exam Online Coaching 2025

23 Courses

₹ 4,999 ~~₹ 5,999~~

17% OFF

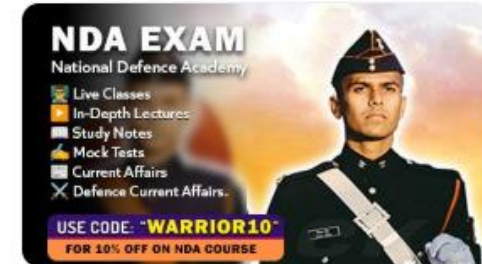

NDA Exam Online Coaching 2025

23 Courses

₹ 4,999 ~~₹ 5,999~~

17% OFF

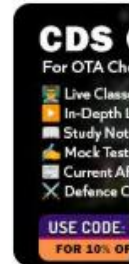

CDS Exam Online Coaching 2025

22 Courses

₹ 4,499



NDA Mock Test Series 2025

40 Tests

₹ 499 ~~₹ 999~~

50% OFF



AFCAT Mock Test Series 2025

20 Tests

₹ 499 ~~₹ 999~~

50% OFF



CDS Exam Mock Test Series 2025

30 Tests

₹ 499 ~~₹ 999~~

50% OFF



CDS OTA Exam Mock Test Series 2025

20 Tests

₹ 499 ~~₹ 999~~

50% OFF



MNS Mock Test Series 2025

20 Tests

₹ 499

India's Most Popular Portal for Defence Exam Preparation

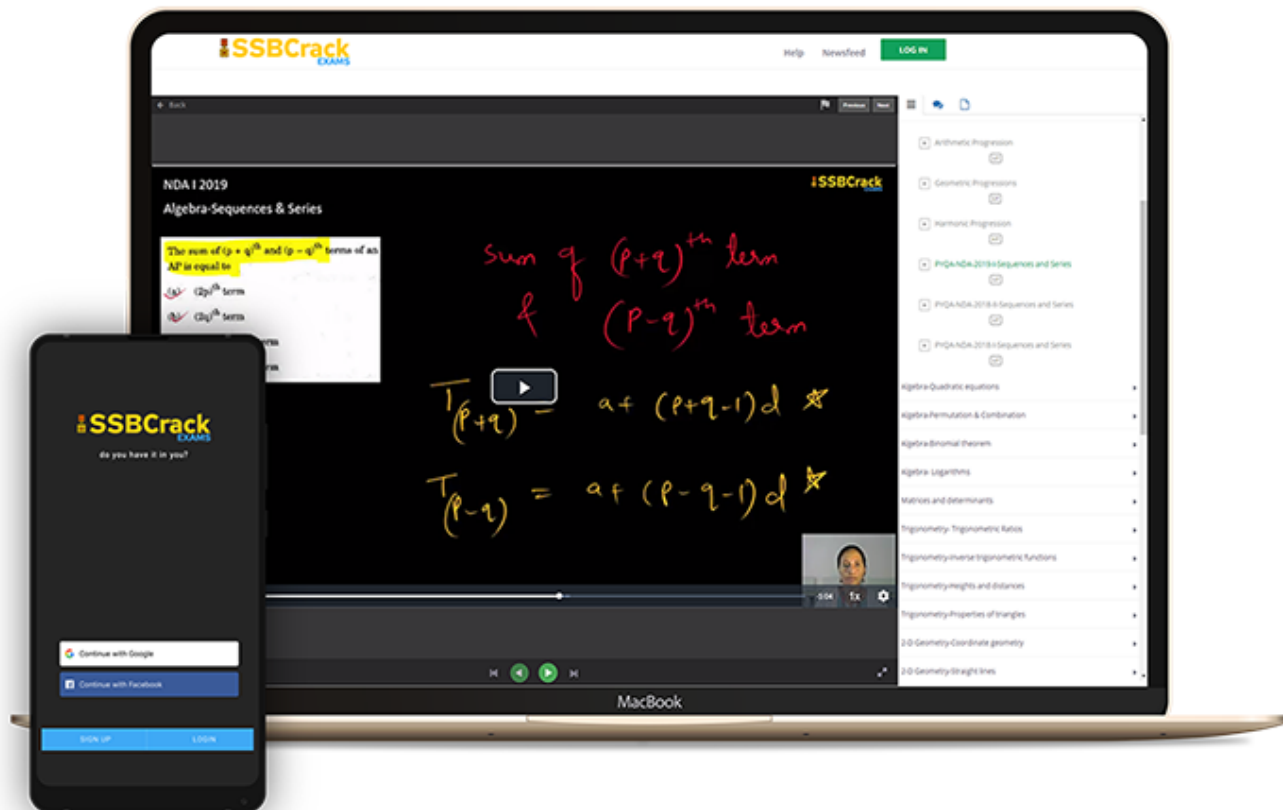

www.ssbcrackexams.com

CODE: WARRIOR10

get an extra 10% off on all courses



Q)The radius of the base of a right circular cone is increased by 15% keeping the height fixed. The volume of the cone will be increased by

- | | |
|------------|------------|
| (a) 30% | (b) 31% |
| (c) 32.25% | (d) 34.75% |

Q)The radius of the base of a right circular cone is increased by 15% keeping the height fixed. The volume of the cone will be increased by

- | | |
|------------|------------|
| (a) 30% | (b) 31% |
| (c) 32.25% | (d) 34.75% |

Ans: (c)

Q) A cloth store is offering buy 3, get 1 free. What is the net percentage discount being offered by the store?

(a) 20%

(b) 25%

(c) 30%

(d) $33\frac{1}{3}\%$

Q) A cloth store is offering buy 3, get 1 free. What is the net percentage discount being offered by the store?

(a) 20%

(b) 25%

(c) 30%

(d) $33\frac{1}{3}\%$

Ans: (b)

Q) In respect of a bill of ₹ 10000, what is the difference between a discount of 40% and two successive discounts of 36% and 4%?

- | | |
|-----------|-----------|
| (a) ₹ 0 | (b) ₹ 144 |
| (c) ₹ 256 | (d) ₹ 400 |

Q) In respect of a bill of ₹ 10000, what is the difference between a discount of 40% and two successive discounts of 36% and 4%?

- | | |
|-----------|-----------|
| (a) ₹ 0 | (b) ₹ 144 |
| (c) ₹ 256 | (d) ₹ 400 |

Ans: (b)

Q)Two articles are sold for ₹9,720 each. On one, the seller gains 8% and on the other, he loses 10%. What is his overall gain or loss?

(a) ₹ 380 gain

(b) ₹ 380 loss

(c) ₹ 360 loss

(d) ₹ 360 gain

Q)Two articles are sold for ₹9,720 each. On one, the seller gains 8% and on the other, he loses 10%. What is his overall gain or loss?

- | | |
|----------------|----------------|
| (a) ₹ 380 gain | (b) ₹ 380 loss |
| (c) ₹ 360 loss | (d) ₹ 360 gain |

Ans: (c)

Q) A shopkeeper bought 120 quintals of wheat. 20% of it was sold at 25% loss. At what percent gain should he sell the rest to gain 25% on the whole transaction?

- (a) $36\frac{1}{2}$ (b) 40 (c) $37\frac{1}{2}$ (d) 35

Q) A shopkeeper bought 120 quintals of wheat. 20% of it was sold at 25% loss. At what percent gain should he sell the rest to gain 25% on the whole transaction?

- (a) $36\frac{1}{2}$ (b) 40 (c) $37\frac{1}{2}$ (d) 35

Ans: (c)

Q) Pipes A, B and C can fill a tank in 30 h, 40 h and 60 h respectively. Pipes A, B and C are opened at 7 a.m., 8 a.m., and 10 a.m.. respectively on the same day. When will the tank be full?

- (a) 10.00 p.m. (b) 10.20 p.m.
(c) 9.20 p.m. (d) 9.40 p.m.

Q) Pipes A, B and C can fill a tank in 30 h, 40 h and 60 h respectively. Pipes A, B and C are opened at 7 a.m., 8 a.m., and 10 a.m.. respectively on the same day. When will the tank be full?

- (a) 10.00 p.m. (b) 10.20 p.m.
(c) 9.20 p.m. (d) 9.40 p.m.

Ans: (c)

Q) It takes 11 hours for a 600 km journey if 120 km is done by train and the rest by car. It takes 40 minutes more if 200 km are covered by train and the rest by car. What is the ratio of speed of the car to that of the train?

- (a) 3 : 2 (b) 2 : 3 (c) 3 : 4 (d) 4 : 3

Q) It takes 11 hours for a 600 km journey if 120 km is done by train and the rest by car. It takes 40 minutes more if 200 km are covered by train and the rest by car. What is the ratio of speed of the car to that of the train?

- (a) 3 : 2 (b) 2 : 3 (c) 3 : 4 (d) 4 : 3

Ans: (a)

Q) 35 persons are engaged to complete a work in 60 days. After 32 days it is observed that only $(\frac{2}{5})$ th part of the work has been done. The number of persons to be engaged to complete the remaining work in the said period is

- (a) 20 (b) 35 (c) 30 (d) 25

Q)35 persons are engaged to complete a work in 60 days. After 32 days it is observed that only $(\frac{2}{5})$ th part of the work has been done. The number of persons to be engaged to complete the remaining work in the said period is

- (a) 20 (b) 35 (c) 30 (d) 25

Ans: (d)

Q)The ratio of investment by A to that by B in a business is 14: 15 and the ratio of their respective profits at the end of a year is 2 : 5. If A invested the money for 3 months, then for how much time (in months) B invested his money?

- (a) 7 (b) 6 (c) 5 (d) 9

Q)The ratio of investment by A to that by B in a business is 14: 15 and the ratio of their respective profits at the end of a year is 2 : 5. If A invested the money for 3 months, then for how much time (in months) B invested his money?

- (a) 7 (b) 6 (c) 5 (d) 9

Ans: (a)

Q) The ratio of the income of A to that of B is 5 : 7. A and B save ₹4,000 and ₹5,000 respectively. If the expenditure of A is equal to $66\frac{2}{3}\%$ of the expenditure of B, then the total income of A and B is:

- | | |
|--------------|--------------|
| (a) ₹ 25,200 | (b) ₹ 24,000 |
| (c) ₹ 26,400 | (d) ₹ 28,800 |

Q) The ratio of the income of A to that of B is 5 : 7. A and B save ₹4,000 and ₹5,000 respectively. If the expenditure of A is equal to $66\frac{2}{3}\%$ of the expenditure of B, then the total income of A and B is:

- | | |
|-------------|-------------|
| (a) ₹25,200 | (b) ₹24,000 |
| (c) ₹26,400 | (d) ₹28,800 |

Ans: (b)

Q) Three taps A, B and C together can fill a tank in 6 hours. Tap C alone can fill the tank in 12 hours. To fill the tank, when it is empty, all the three taps are started together. After working t hours, tap C is closed and the tank is filled in 8 more hours. What is t equal to ?

- (a) 1
- (b) 2
- (c) 4
- (d) 6

Q) Three taps A, B and C together can fill a tank in 6 hours. Tap C alone can fill the tank in 12 hours. To fill the tank, when it is empty, all the three taps are started together. After working t hours, tap C is closed and the tank is filled in 8 more hours. What is t equal to ?

- (a) 1
- (b) 2
- (c) 4
- (d) 6

Ans: (b)

Q)When the Speed of a train is increased by 20%, it takes 20 minutes less to cover the same distance. What is the time taken to cover the same distance with the original speed ?

- | | |
|-----------------|-----------------|
| (a) 140 minutes | (b) 120 minutes |
| (c) 100 minutes | (d) 80 minutes |

Q)When the Speed of a train is increased by 20%, it takes 20 minutes less to cover the same distance. What is the time taken to cover the same distance with the original speed ?

- | | |
|-----------------|-----------------|
| (a) 140 minutes | (b) 120 minutes |
| (c) 100 minutes | (d) 80 minutes |

Ans: (b)

- Q)** Ram had ₹ 2 lakh, part of which he lent at 15% per annum and rest at 12% per annum. Yearly interest accrued was ₹ 27600. How much did he lent at 15%?
- (a) ₹ 120000 (b) ₹ 100000
(c) ₹ 80000 (d) ₹ 60000

- Q)** Ram had ₹ 2 lakh, part of which he lent at 15% per annum and rest at 12% per annum. Yearly interest accrued was ₹ 27600. How much did he lent at 15%?
- (a) ₹ 120000 (b) ₹ 100000
(c) ₹ 80000 (d) ₹ 60000

Ans: (a)

Q) If the difference between S.I and C.I for 2 years on a sum of money lent at 5% is ₹ 6, then the sum B.

- (a) ₹ 2200 (b) ₹ 2400 (c) ₹ 2600 (d) ₹ 2000

Q) If the difference between S.I and C.I for 2 years on a sum of money lent at 5% is ₹ 6, then the sum B.

- (a) ₹ 2200 (b) ₹ 2400 (c) ₹ 2600 (d) ₹ 2000

Ans: (b)

Q) Three coins are tossed together, then the probability of getting at least one head is

(a) $\frac{1}{2}$

(b) $\frac{3}{4}$

(c) $\frac{1}{8}$

(d) $\frac{7}{8}$

Q) Three coins are tossed together, then the probability of getting at least one head is

(a) $\frac{1}{2}$

(b) $\frac{3}{4}$

(c) $\frac{1}{8}$

(d) $\frac{7}{8}$

Ans: (d)

Q) A person borrowed ₹ 7500 at 16% compound interest. How much does he have to pay at the end of 2 years to clear the loan ?

(a) ₹ 9900

(b) ₹ 10092

(c) ₹ 11000

(d) ₹ 11052

Q) A person borrowed ₹ 7500 at 16% compound interest. How much does he have to pay at the end of 2 years to clear the loan ?

- | | |
|-------------|-------------|
| (a) ₹ 9900 | (b) ₹ 10092 |
| (c) ₹ 11000 | (d) ₹ 11052 |

Ans: (b)

Q)The area enclosed between the circumferences of two concentric circles is 16π sq cm and their radii are in the ratio $5 : 3$. What is the area of the outer circle?

- | | |
|-------------------|-------------------|
| (a) 9π sq cm | (b) 16π sq cm |
| (c) 25π sq cm | (d) 36π sq cm |

Q)The area enclosed between the circumferences of two concentric circles is 16π sq cm and their radii are in the ratio $5 : 3$. What is the area of the outer circle?

- (a) 9π sq cm (b) 16π sq cm
(c) 25π sq cm (d) 36π sq cm

Ans: (c)

Q) A rectangular lawn $70\text{ m} \times 30\text{ m}$ has two roads each 5 metres wide, running in the middle of it, one parallel to the length and the other parallel to the breadth. Find the cost of gravelling the road at the rate of ₹ 4 per square metre.

- | | |
|-------------|-------------|
| (a) ₹ 2,000 | (b) ₹ 1,800 |
| (c) ₹ 1,900 | (d) ₹ 1,700 |

- Q)** A rectangular lawn $70\text{ m} \times 30\text{ m}$ has two roads each 5 metres wide, running in the middle of it, one parallel to the length and the other parallel to the breadth. Find the cost of gravelling the road at the rate of ₹ 4 per square metre.
- (a) ₹ 2,000 (b) ₹ 1,800
(c) ₹ 1,900 (d) ₹ 1,700

Ans: (c)

Q) The area of a square inscribed in a circle of radius 8 cm is

(a) 32 sq cm

(b) 64 sq cm

(c) 128 sq cm

(d) 256 sq cm

Q) The area of a square inscribed in a circle of radius 8 cm is

(a) 32 sq cm

(b) 64 sq cm

(c) 128 sq cm

(d) 256 sq cm

Ans: (c)

Q) From a pack of 52 cards two cards are drawn in succession one by one without replacement. The probability that both are aces is

- | | |
|---------------------|--------------------|
| (a) $\frac{2}{13}$ | (b) $\frac{1}{51}$ |
| (c) $\frac{1}{221}$ | (d) $\frac{2}{21}$ |

Q) From a pack of 52 cards two cards are drawn in succession one by one without replacement. The probability that both are aces is

- | | |
|---------------------|--------------------|
| (a) $\frac{2}{13}$ | (b) $\frac{1}{51}$ |
| (c) $\frac{1}{221}$ | (d) $\frac{2}{21}$ |

Ans: (c)

Q) A, B and C can complete a work in x , $1.5x$ and $2x$ days respectively. If they complete the work together, in what ratio should they be paid ?

- (a) $2 : 3 : 4$
- (b) $6 : 4 : 3$
- (c) $3 : 2 : 1$
- (d) $4 : 3 : 2$

Q) A, B and C can complete a work in x , $1.5x$ and $2x$ days respectively. If they complete the work together, in what ratio should they be paid ?

- (a) $2 : 3 : 4$
- (b) $6 : 4 : 3$
- (c) $3 : 2 : 1$
- (d) $4 : 3 : 2$

Ans: (b)

Q)An aeroplane flies along the four sides of a square at a speed of 100, 200, 300 and 400 km/h, respectively. What is the average speed of the plane in its flight around the square?

- (a) 196 km/h (b) 200 km/h
(c) 250 km/h (d) None of these

Q)An aeroplane flies along the four sides of a square at a speed of 100, 200, 300 and 400 km/h, respectively. What is the average speed of the plane in its flight around the square?

- (a) 196 km/h (b) 200 km/h
(c) 250 km/h (d) None of these

Ans: (d)

Q) If the average of 9 consecutive positive integers is 55, then what is the largest integer?

(a) 57

(b) 58

(c) 59

(d) 60

Q) If the average of 9 consecutive positive integers is 55, then what is the largest integer?

(a) 57

(b) 58

(c) 59

(d) 60

Ans: (c)

- Q)** Three runners are running in a circular track, and they complete one round in 20, 30 and 35 minutes respectively. when will they next meet at the starting point?
- (a) After 3 hour 30 minutes
 - (b) After 4 hour 30 minutes
 - (c) After 3 hour
 - (d) After 7 hour

- Q)** Three runners are running in a circular track, and they complete one round in 20, 30 and 35 minutes respectively. when will they next meet at the starting point?
- (a) After 3 hour 30 minutes
 - (b) After 4 hour 30 minutes
 - (c) After 3 hour
 - (d) After 7 hour

Ans: (d)

Q) What is the remainder after dividing the number 37^{1000} by 9?

(a) 1

(b) 3

(c) 7

(d) 9

Q) What is the remainder after dividing the number 37^{1000} by 9?

(a) 1

(b) 3

(c) 7

(d) 9

Ans: (a)





SSB Interview Online Coaching 2025

SSB Interview: 📺 Live Classes ▶ In-Depth Lectures 📖 SSB Notes 🔥 Mock Tests 📅 Current Affairs ✂ Defence Current Affairs.

★★★★★ 5.0 (253)

Content 18

🔍 FILTER BY TYPE ▾

-  **SSB Live Batch January 2025**
Course • 969 Lessons 11 Trials
-  **SSB Live Batch February 2025 - Enroll Now**
Course • 1 Lessons 1 Trial
-  **Basics of SSB Interview**
Course • 68 Lessons
-  **OIR Test - Verbal Reasoning - Part 1**
Course • 618 Lessons
-  **OIR Test - Verbal Reasoning - Part 2**
Course • 401 Lessons



SSB INTERVIEW
For SSB, AFSB & NSB.

- 📺 Live Classes
- ▶ In-Depth Lectures
- 📖 SSB Notes
- 🔥 Mock Tests
- 📅 Current Affairs
- ✂ Defence Current Affairs

USE CODE: **WARRIOR10**
FOR 10% OFF ON SSB COURSE

🕒 365 Days validity

₹ 6,999 ~~₹ 9,999~~ 30% OFF

[BUY BUNDLE](#)

[START A FREE TRIAL](#)

What's included

📅 18 Courses

Other Pricing Plans

Validity 30 Days

30 Days Validity

[Details](#)

₹4,999 ~~₹5,999~~ 17% off

[BUY NOW](#)





AFCAT Exam Online Coaching 2025

AFCAT 2025: 📺 Live Classes ▶ In-Depth Lectures 📖 Study Notes 🚩 Mock Tests 📅 Current Affairs ✂ Defence Current Affairs.

★★★★★ 5.0 (147)

Content 22

Search in bundle 🔍 FILTER BY TYPE ▾

- 
AFCAT 1 2025 Live Batch - 2
 Course • 331 Lessons
- 
AFCAT 2 2024 Exam Answerkey | 09 - 11 Aug 2024 | Shift 1 & 2
 Course • 228 Lessons 1 Trial
- 
AFCAT 1 2024 Live Batch - 2
 Course • 148 Lessons 2 Trials
- 
AFCAT 1 2024 Live Batch - 1
 Course • 315 Lessons 1 Trial
- 
AFCAT Exam Overview
 Course • 26 Lessons



AFCAT
Air Force Common Admission Test

- 📺 Live Classes
- 🎓 In-Depth Lectures
- 📖 Study Notes
- 🚩 Mock Tests
- 📅 Current Affairs
- ✂ Defence Current Affairs

USE CODE: **"WARRIOR10"**
FOR 10% OFF ON THIS COURSE

🕒 180 Days validity

₹ 4,999 ~~₹ 5,999~~ 17% OFF

[BUY BUNDLE](#)

[START A FREE TRIAL](#)

What's included

📅 22 Courses

Other Pricing Plans

Validity 12 Months

365 Days Validity

[Details](#)

₹5,999 ~~₹7,999~~ 25% off

[BUY NOW](#)



Sainik School Exam Course for Class 6

5 Courses

₹ 2,999 ~~₹ 5,999~~ 50% OFF



SSB Interview Online Coaching 2025

18 Courses

₹ 6,999 ~~₹ 9,999~~ 30% OFF

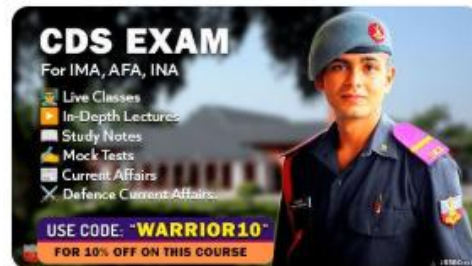

CDS Exam Online Coaching 2025

23 Courses

₹ 4,999 ~~₹ 5,999~~ 17% OFF

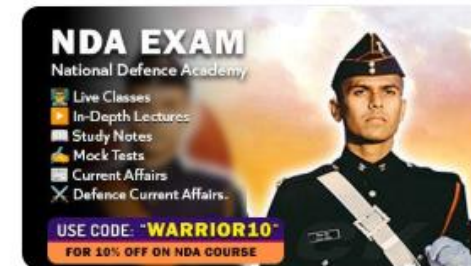

NDA Exam Online Coaching 2025

23 Courses

₹ 4,999 ~~₹ 5,999~~ 17% OFF

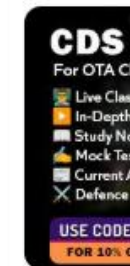

CDS Exam Online Coaching 2025

22 Courses

₹ 4,499

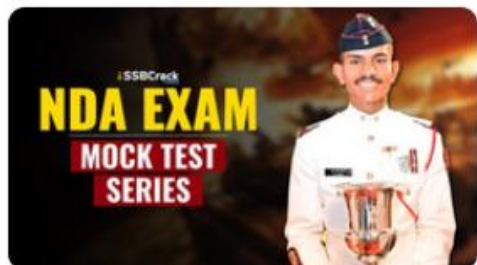

NDA Mock Test Series 2025

40 Tests

₹ 499 ~~₹ 999~~ 50% OFF



AFCAT Mock Test Series 2025

20 Tests

₹ 499 ~~₹ 999~~ 50% OFF



CDS Exam Mock Test Series 2025

30 Tests

₹ 499 ~~₹ 999~~ 50% OFF



CDS OTA Exam Mock Test Series 2025

20 Tests

₹ 499 ~~₹ 999~~ 50% OFF



MNS Mock Test Series 2025

20 Tests

₹ 499

India's Most Popular Portal for Defence Exam Preparation

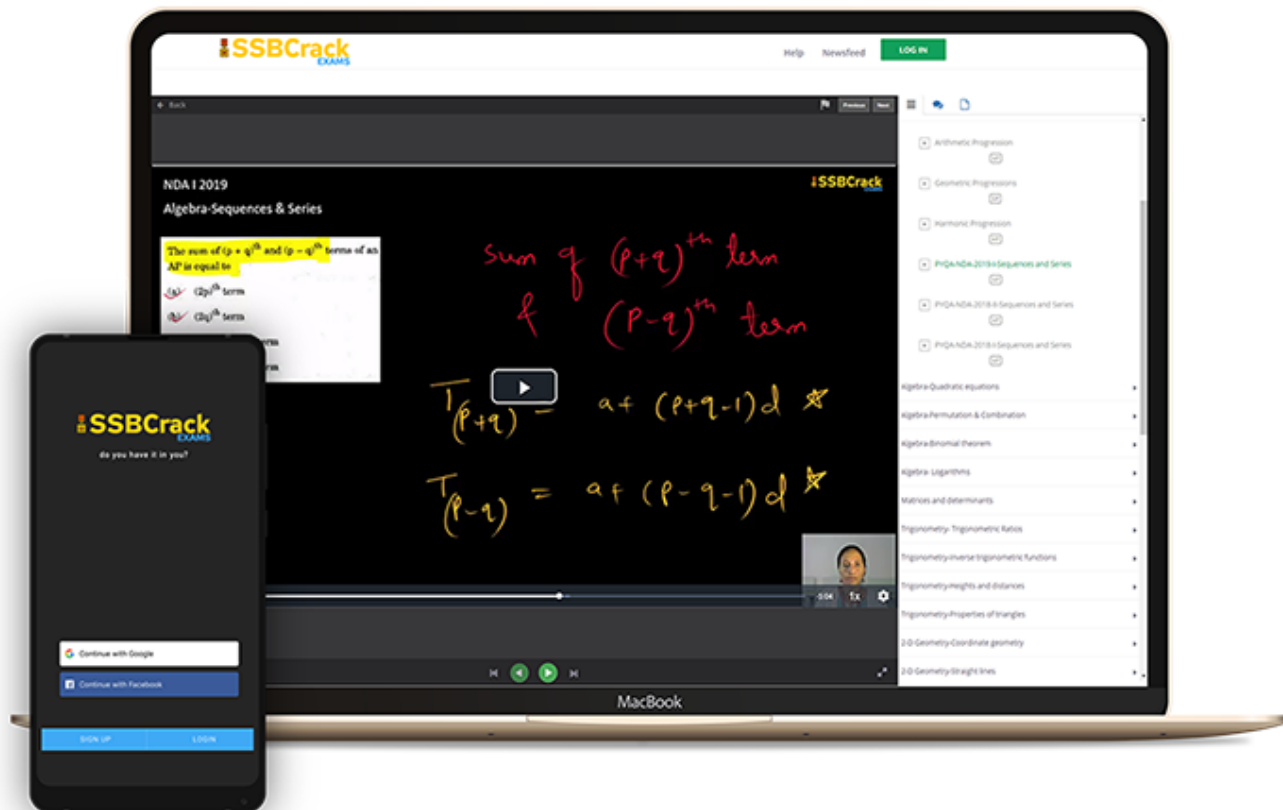

www.ssbcrackexams.com

CODE: WARRIOR10

get an extra 10% off on all courses





AFCAT 1 2025

MAHA MARATHON #1



COMPLETE REVISION

19 FEB 2025

12 PM TO 04 PM



LIVE CLASS



AFCAT 1 2025

MAHA MARATHON

19 TO 21 FEB 2025

12 PM TO 01 PM

MATHS - NAVJYOTI SIR

01 PM TO 02 PM

ENGLISH - ANURADHA MA'AM

02 PM TO 03 PM

REASONING - RUBY MA'AM

03 PM TO 04 PM

STATIC GK - DIVYANSHU SIR

 CALL US: 080-69185400

 GET IT ON
Google Play

DOWNLOAD
THE APP NOW





AFCAT Exam Online Coaching 2025

AFCAT 2025: Live Classes In-Depth Lectures Study Notes Mock Tests Current Affairs Defence Current Affairs.

★★★★★ 5.0 (147)

Content 22

- Search in bundle FILTER BY TYPE
- 

AFCAT 1 2025 Live Batch - 2
Course • 331 Lessons
 - 

AFCAT 2 2024 Exam Answerkey | 09 - 11 Aug 2024 | Shift 1 & 2
Course • 228 Lessons 1 Trial
 - 

AFCAT 1 2024 Live Batch - 2
Course • 148 Lessons 2 Trials
 - 

AFCAT 1 2024 Live Batch - 1
Course • 315 Lessons 1 Trial
 - 

AFCAT Exam Overview
Course • 26 Lessons



180 Days validity

₹ 4,999 ~~₹ 5,999~~ 17% OFF

BUY BUNDLE

START A FREE TRIAL

What's included

22 Courses

Other Pricing Plans

Validity 12 Months

365 Days Validity

[Details](#)

₹5,999 ~~₹7,999~~ 25% off

BUY NOW

Bundles 13

[View All](#)



Sainik School Exam Course for Class 6

5 Courses

₹ 2,999 ~~₹ 5,999~~ 50% OFF



SSB Interview Online Coaching 2025

18 Courses

₹ 6,999 ~~₹ 9,999~~ 30% OFF

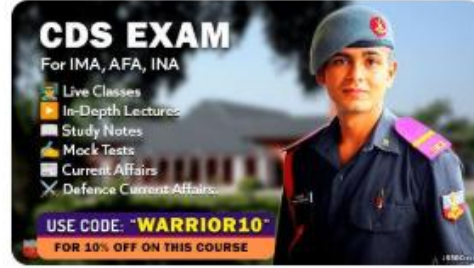

CDS Exam Online Coaching 2025

23 Courses

₹ 4,999 ~~₹ 5,999~~ 17% OFF

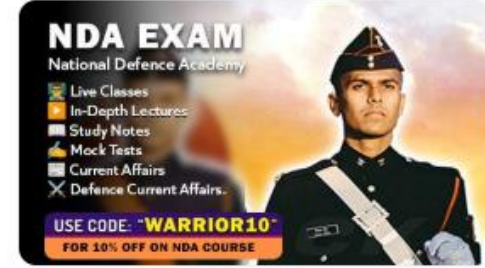

NDA Exam Online Coaching 2025

23 Courses

₹ 4,999 ~~₹ 5,999~~ 17% OFF

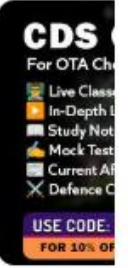

CDS Exam Online Coaching 2025

22 Courses

₹ 4,499

Test series 07

[View All](#)

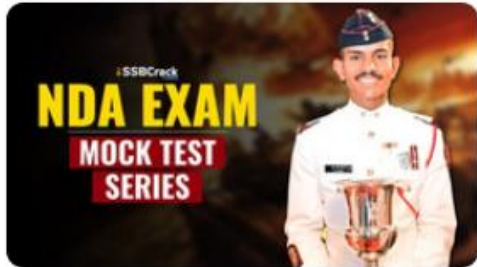

NDA Mock Test Series 2025

40 Tests

₹ 499 ~~₹ 999~~ 50% OFF



AFCAT Mock Test Series 2025

20 Tests

₹ 499 ~~₹ 999~~ 50% OFF



CDS Exam Mock Test Series 2025

30 Tests

₹ 499 ~~₹ 999~~ 50% OFF



CDS OTA Exam Mock Test Series 2025

20 Tests

₹ 499 ~~₹ 999~~ 50% OFF



MNS Mock Test Series 2025

20 Tests

₹ 499

India's Most Popular Portal for Defence Exam Preparation

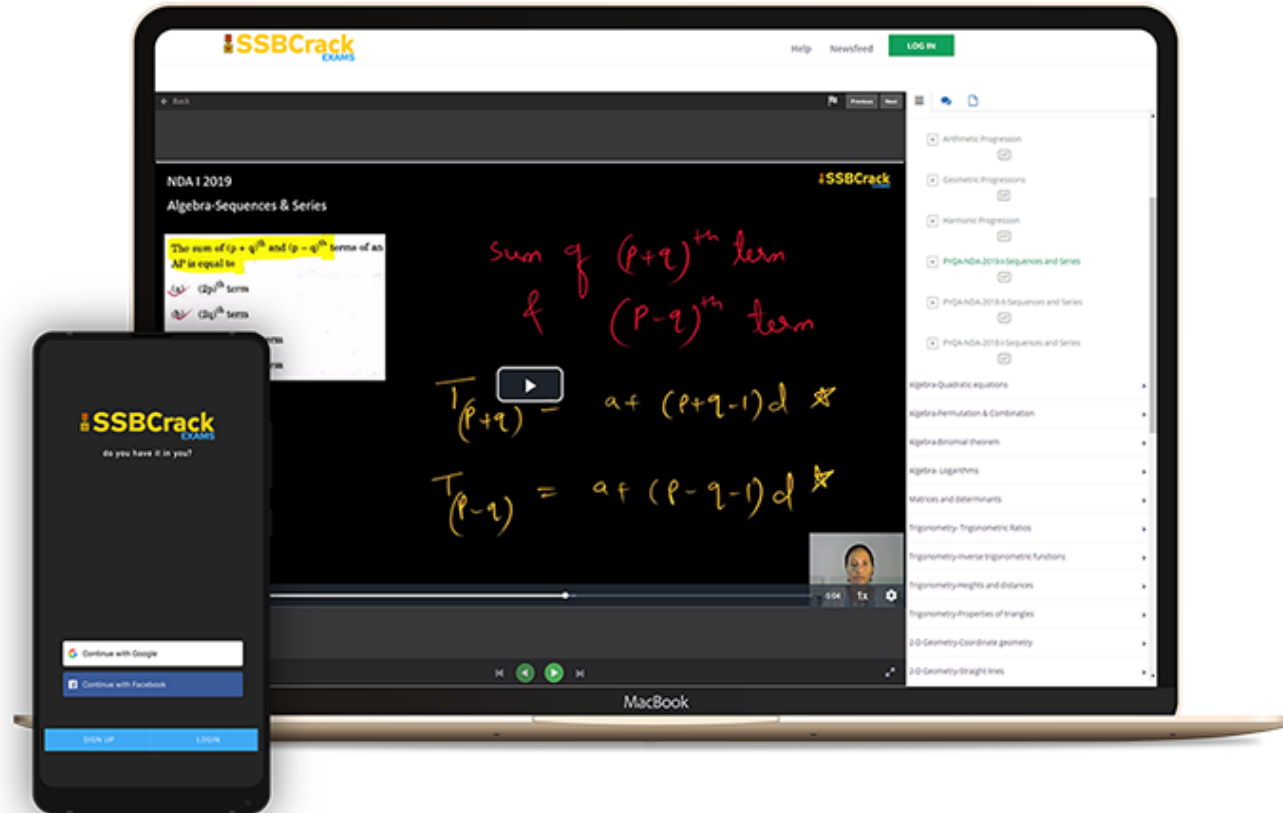

www.ssbcrackexams.com

CODE: WARRIOR10

get an extra **10%** off on all courses



DIRECTIONS

Read the passage carefully and choose the best answer to each question out of the four alternatives.

The greatest thing this age can be proud of is the birth of man in the consciousness of men. In his drunken orgies of power and national pride man may flout and jeer at it. When organised national selfishness, racial antipathy and commercial self seeking begin to display their ugly deformities in all their nakedness, then comes the time for man to know that his salvation is not in political organisations and extended trade relations, not in any mechanical re-arrangement of social system but in a deeper transformation of life, in the liberation of consciousness in love, in the realization of God in man.

Q. In this passage, the phrase "God in man" implies

- a) God having assumed the shape of man
- b) neither fully godly nor fully human
- c) man being transformed into God
- d) the divine qualities in man

0:20

Q. In this passage, the phrase "God in man" implies

- a) God having assumed the shape of man
- b) neither fully godly nor fully human
- c) man being transformed into God
- d) the divine qualities in man

Ans. (d)

- Q.** The author uses the expression 'ugly deformities' to show his indignation at
- a) political organisations
 - b) the liberation of human consciousness
 - c) selfishness and materialism of the people
 - d) the drunken orgies of power



0:20

- Q.** The author uses the expression 'ugly deformities' to show his indignation at
- a) political organisations
 - b) the liberation of human consciousness
 - c) selfishness and materialism of the people
 - d) the drunken orgies of power

Ans. (c)

Q. According to the author, "salvation" of human beings lies in the

- a) extended trade relations
- b) spiritual transformation of life
- c) orgy of national pride
- d) wholehearted participation in political organisations



0:20

Q. According to the author, "salvation" of human beings lies in the

- a) extended trade relations
- b) spiritual transformation of life
- c) orgy of national pride
- d) wholehearted participation in political organisations

Ans. (b)

Q. In the phrase "the birth of Man in the consciousness of men", Man stands for

- a) power and arrogance
- b) egocentricity
- c) Good qualities
- d) an idealistic notion of the human self

0:20

Q. In the phrase "the birth of Man in the consciousness of men", Man stands for

- a) power and arrogance
- b) egocentricity
- c) Good qualities
- d) an idealistic notion of the human self

Ans. (d)

- Q.** People jeer at the 'birth of Man' in the human consciousness when they
- a) begin to think of themselves as God
 - b) become power hungry
 - c) restructure the social system
 - d) become mentally deranged



0:20

- Q.** People jeer at the 'birth of Man' in the human consciousness when they
- a) begin to think of themselves as God
 - b) become power hungry
 - c) restructure the social system
 - d) become mentally deranged

Ans. (b)

DIRECTIONS

In the following questions, the sentence given with blank to be filled in with an appropriate word. Select the correct alternative out of the four and indicate it by selecting the appropriate option.

Q. Man has won his dominant position on this planet by his _____ of technology.

(a) command

(b) emphasis

(c) belief

(d) stress

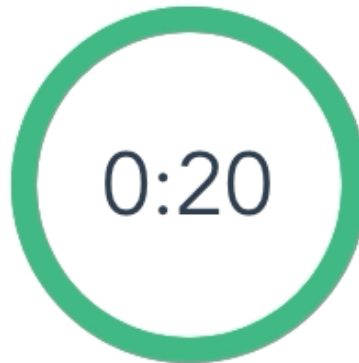

Q. Man has won his dominant position on this planet by his _____ of technology.

(a) command

(b) emphasis

(c) belief

(d) stress

Ans. (a)

Q. The day was extremely hot and, in no time, my back was drenched with _____.

(a) prickly heat

(b) perspiration

(c) sores

(d) fatigue

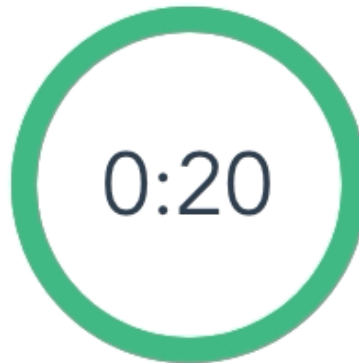

Q. The day was extremely hot and, in no time, my back was drenched with _____.

(a) prickly heat

(b) perspiration

(c) sores

(d) fatigue

Ans. (b)

Q. The Government is encouraging village upliftment _____ in the country.

(a) programmes

(b) designs

(c) talks

(d) propaganda

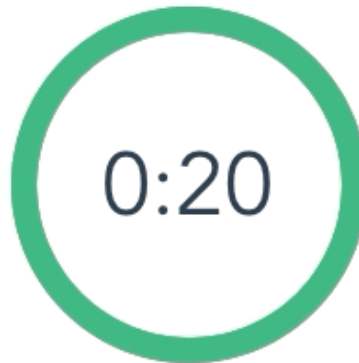

Q. The Government is encouraging village upliftment _____ in the country.

(a) programmes

(b) designs

(c) talks

(d) propaganda

Ans. (a)

Q. Satish was endowed _____ a natural talent for music.

(a) in

(b) by

(c) for

(d) with

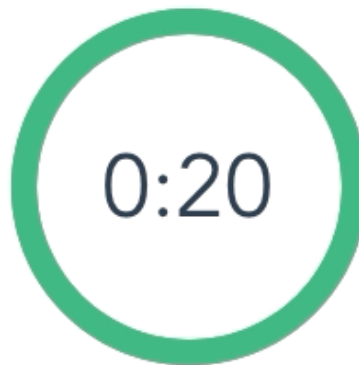

Q. Satish was endowed _____ a natural talent for music.

(a) in

(b) by

(c) for

(d) with

Ans. (d)

Q. Mr. Ghosh is very happy _____ his son's excellent result.

(a) for seeing

(b) to see

(c) by seeing

(d) see

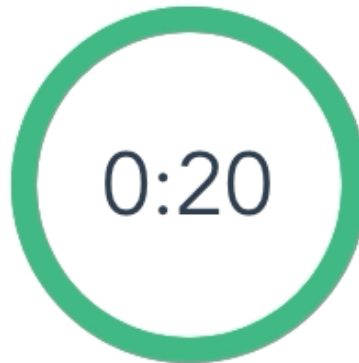

Q. Mr. Ghosh is very happy _____ his son's excellent result.

(a) for seeing

(b) to see

(c) by seeing

(d) see

Ans. (b)

Q. Sunlight filtering _____ the stained glass window created a mosaic of colours on the floor.

(a) in

(b) through

(c) at

(d) into

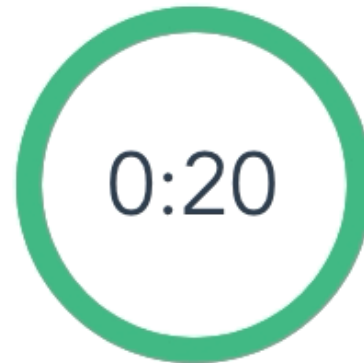

Q. Sunlight filtering _____ the stained glass window created a mosaic of colours on the floor.

(a) in

(b) through

(c) at

(d) into

Ans. (b)

DIRECTIONS

In each of the question part, find out which part has an error. If there is no mistake, the answer is 'No error'.

Q. Neither of the girls (a)/ were willing to (b)/ accept the proposal. (c)/ No error (d)

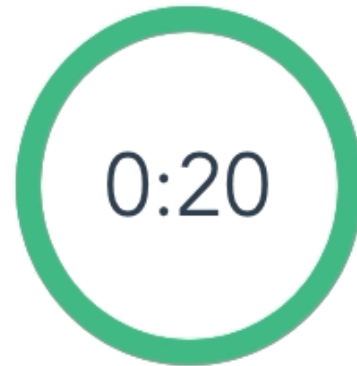

Q. Neither of the girls (a)/ were willing to (b)/ accept the proposal. (c)/ No error (d)

Ans. (b)

Q. Shakespeare has written (a)/ many plays (b)/ as well as some poetries. (c) / No error
(d)

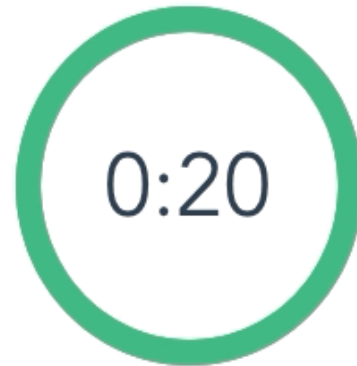

Q. Shakespeare has written (a)/ many plays (b)/ as well as some poetries. (c) / No error
(d)

Ans. (c)

Q. I worked (a)/ as medical representative (b)/ for eight months. (c)/ No error (d)

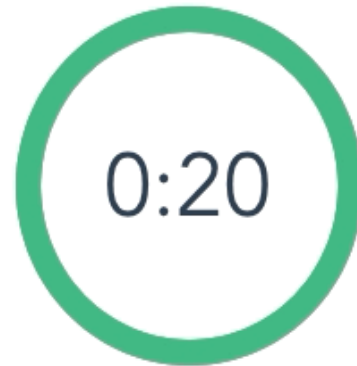

Q. I worked (a)/ as medical representative (b)/ for eight months. (c)/ No error (d)

Ans. (d)

Q. If life existed on Mars, it is most likely to be in (a)/ the form of bacteria buried deep in (b)/ the planet's permafrost or lichens. (c)/ No error (d)

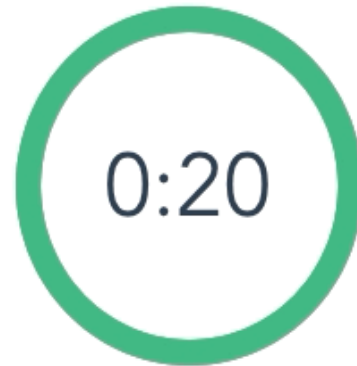

Q. If life existed on Mars, it is most likely to be in (a)/ the form of bacteria buried deep in (b)/ the planet's permafrost or lichens. (c)/ No error (d)

Ans. (a)

DIRECTIONS

Choose the alternative which best expresses the meaning of the Idiom/ Phrase that is your answer.

Q. To be in a fix

(a) In pain

(b) In distress

(c) Depressed

(d) In a difficult situation

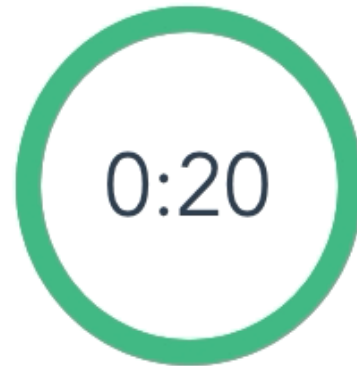

Q. To be in a fix

(a) In pain

(b) In distress

(c) Depressed

(d) In a difficult situation

Ans. (d)

Q. To keep in abeyance

- (a) In a state of permanence
- (b) In a state of emergency
- (c) In a state of suspension
- (d) In a state of revision

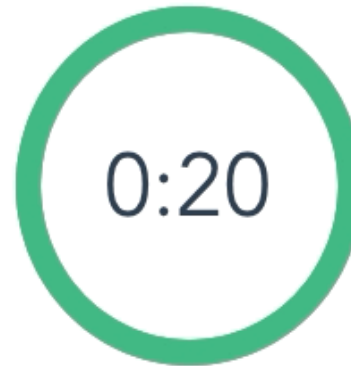

Q. To keep in abeyance

- (a) In a state of permanence
- (b) In a state of emergency
- (c) In a state of suspension
- (d) In a state of revision

Ans. (c)

Q. Seamy side

- (a) the softer aspects
- (b) the unpleasant aspects
- (c) the pleasanter aspects
- (d) the gentler aspects

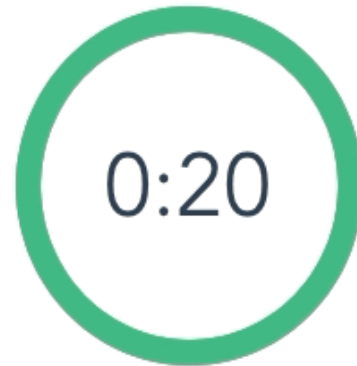

Q. Seamy side

- (a) the softer aspects
- (b) the unpleasant aspects
- (c) the pleasanter aspects
- (d) the gentler aspects

Ans. (b)

Q. Dog's breakfast

(a) A total mess

(b) A breakfast for the dogs

(c) An accurate summary

(d) A breakfast being served by the dogs

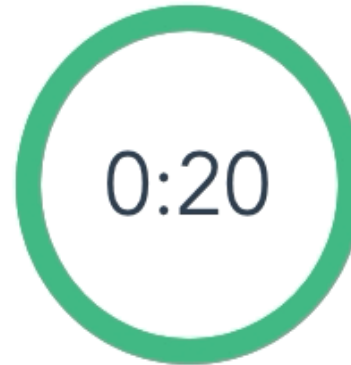

Q. Dog's breakfast

(a) A total mess

(b) A breakfast for the dogs

(c) An accurate summary

(d) A breakfast being served by the dogs

Ans. (a)

Q. To shun evil company

(a) To kick out evil company

(b) To give up evil company

(c) To put off evil company

(d) To let loose evil company

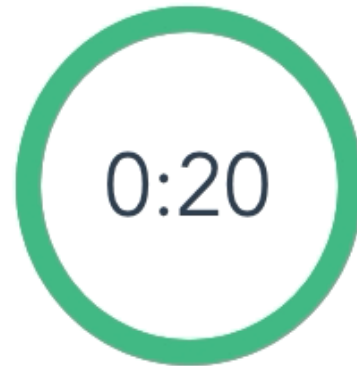

Q. To shun evil company

(a) To kick out evil company

(b) To give up evil company

(c) To put off evil company

(d) To let loose evil company

Ans. (b)

DIRECTIONS

In the following questions, choose the correct synonym.

Q. Loquacious

(a) Talkative

(b) Slow

(c) Content

(d) Unclear

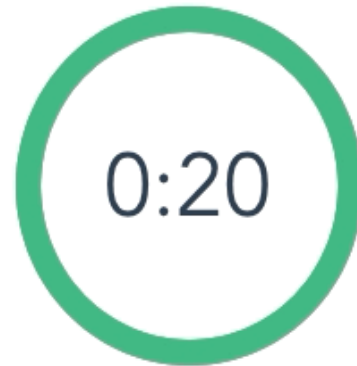

Q. Loquacious

(a) Talkative

(b) Slow

(c) Content

(d) Unclear

Ans. (a)

Q. Vapid

(a) Virtuous

(b) Vital

(c) Priceless

(d) Dull

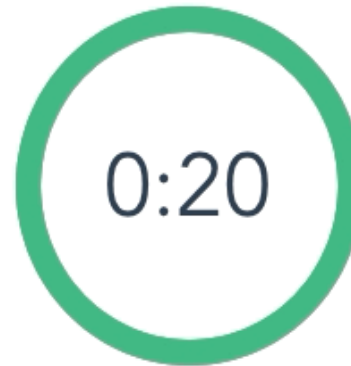

Q. Vapid

(a) Virtuous

(b) Vital

(c) Priceless

(d) Dull

Ans. (d)

Q. Thrive

(a) Hurt

(b) Persuade

(c) Push

(d) Flourish

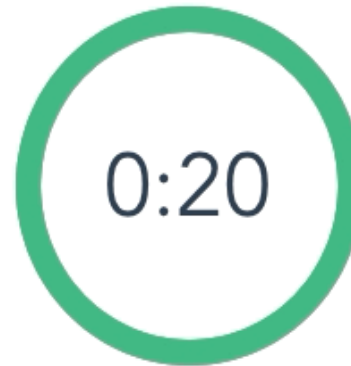

Q. Thrive

(a) Hurt

(b) Persuade

(c) Push

(d) Flourish

Ans. (d)

Q. Exacerbate

(a) Irritate

(b) Enlighten

(c) Aggravate

(d) Exaggerate

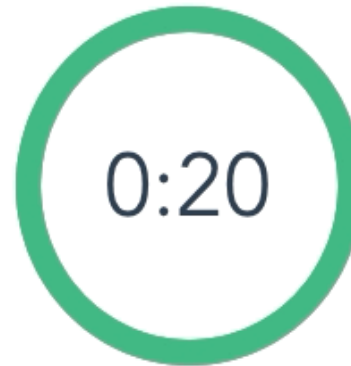

Q. Exacerbate

(a) Irritate

(b) Enlighten

(c) Aggravate

(d) Exaggerate

Ans. (c)

Q. Annotation

(a) Translation

(b) Prologue

(c) Quip

(d) Explanatory note

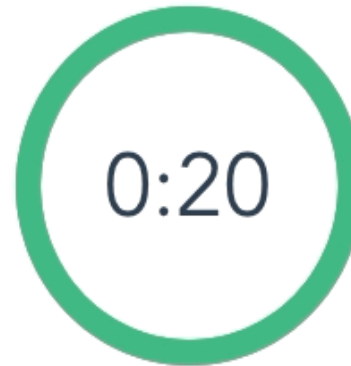

Q. Annotation

(a) Translation

(b) Prologue

(c) Quip

(d) Explanatory note

Ans. (d)

DIRECTIONS

In the following questions, choose the correct antonym.

Q. Effeminacy

- (a) Manliness
- (b) Boorishness
- (c) Aggressiveness
- (d) Attractiveness

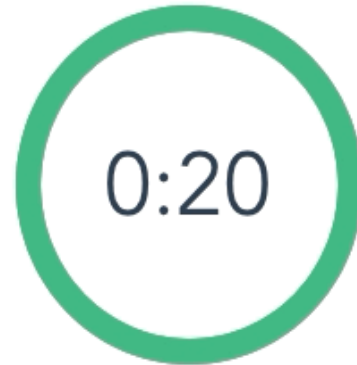

Q. Effeminacy

- (a) Manliness
- (b) Boorishness
- (c) Aggressiveness
- (d) Attractiveness

Ans. (a)

Q. Placid

(a) Dull

(b) Stormy

(c) Urgent

(d) Moving

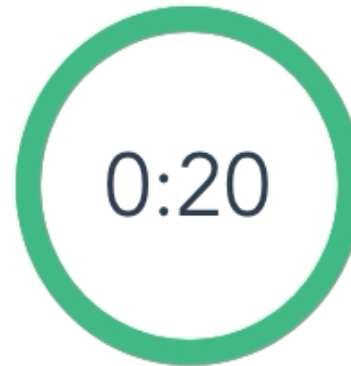

Q. Placid

(a) Dull

(b) Stormy

(c) Urgent

(d) Moving

Ans. (b)

Q. Vacillation

- (a) Inoculation
- (b) Relief
- (c) Steadfastness
- (d) Remorse

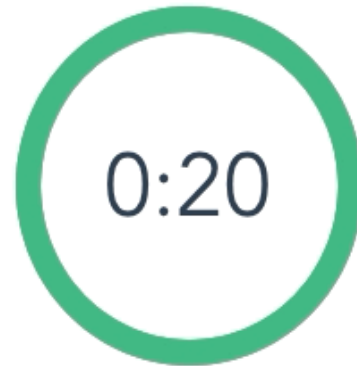

Q. Vacillation

- (a) Inoculation
- (b) Relief
- (c) Steadfastness
- (d) Remorse

Ans. (c)

Q. Embellish

(a) Perish

(b) Disarm

(c) Adorn

(d) Disfigure

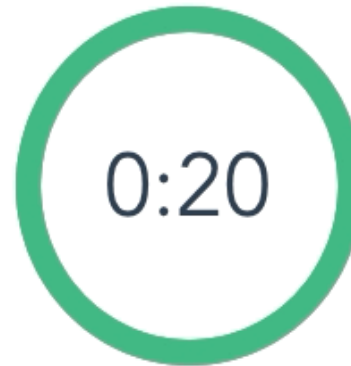

Q. Embellish

(a) Perish

(b) Disarm

(c) Adorn

(d) Disfigure

Ans. (d)

Q. Heterogeneous

(a) Colourful

(b) Different

(c) Similar

(d) Homogeneous

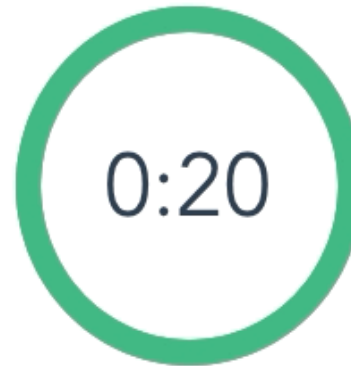

Q. Heterogeneous

- (a) Colourful
- (b) Different
- (c) Similar
- (d) Homogeneous

Ans. (d)

DIRECTIONS

In these questions, in the following passage some of the words have been left out. Read the passage carefully and choose the correct out of four alternatives.

Democracy has its dangers, the greatest of which is that it may be the rule of ignorance. Citizens, who are not **(1)** intelligent and educated, are **(2)** to commit errors of judgement in the casting of votes. The best men may thus **(3)** to get elected. Elections are usually a **(4)** of propaganda. Another criticism of democracy is that it is wanting **(5)** efficiency.

Q1) (a) barely (b) sufficiently (c) highly (d) perfectly

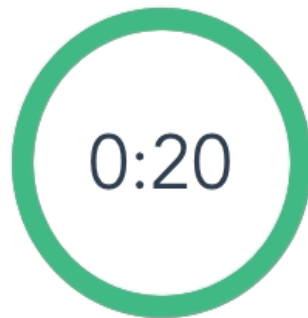

Democracy has its dangers, the greatest of which is that it may be the rule of ignorance. Citizens, who are not **(1)** intelligent and educated, are **(2)** to commit errors of judgement in the casting of votes. The best men may thus **(3)** to get elected. Elections are usually a **(4)** of propaganda. Another criticism of democracy is that it is wanting **(5)** efficiency.

Q1) (a) barely (b) sufficiently (c) highly (d) perfectly

Ans. (b)

Democracy has its dangers, the greatest of which is that it may be the rule of ignorance. Citizens, who are not **(1)** intelligent and educated, are **(2)** to commit errors of judgement in the casting of votes. The best men may thus **(3)** to get elected. Elections are usually a **(4)** of propaganda. Another criticism of democracy is that it is wanting **(5)** efficiency.

Q2) (a) sure (b) deliberately (c) unlikely (d) likely

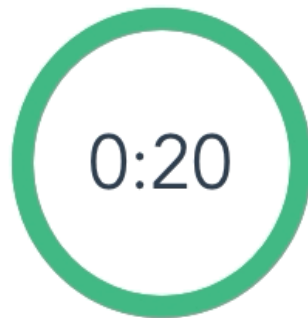

Democracy has its dangers, the greatest of which is that it may be the rule of ignorance. Citizens, who are not **(1)** intelligent and educated, are **(2)** to commit errors of judgement in the casting of votes. The best men may thus **(3)** to get elected. Elections are usually a **(4)** of propaganda. Another criticism of democracy is that it is wanting **(5)** efficiency.

Q2) (a) sure (b) deliberately (c) unlikely (d) likely

Ans. (d)

Democracy has its dangers, the greatest of which is that it may be the rule of ignorance. Citizens, who are not **(1)** intelligent and educated, are **(2)** to commit errors of judgement in the casting of votes. The best men may thus **(3)** to get elected. Elections are usually a **(4)** of propaganda. Another criticism of democracy is that it is wanting **(5)** efficiency.

Q3) (a) fail (b) succeed (c) try (d) desire

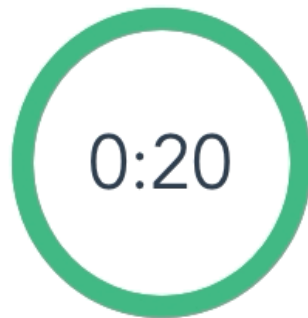

Democracy has its dangers, the greatest of which is that it may be the rule of ignorance. Citizens, who are not **(1)** intelligent and educated, are **(2)** to commit errors of judgement in the casting of votes. The best men may thus **(3)** to get elected. Elections are usually a **(4)** of propaganda. Another criticism of democracy is that it is wanting **(5)** efficiency.

Q3) (a) fail (b) succeed (c) try (d) desire

Ans. (a)

Democracy has its dangers, the greatest of which is that it may be the rule of ignorance. Citizens, who are not **(1)** intelligent and educated, are **(2)** to commit errors of judgement in the casting of votes. The best men may thus **(3)** to get elected. Elections are usually a **(4)** of propaganda. Another criticism of democracy is that it is wanting **(5)** efficiency.

Q4) (a) kind (b) process (c) matter (d) result

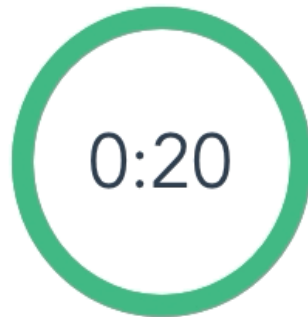

Democracy has its dangers, the greatest of which is that it may be the rule of ignorance. Citizens, who are not **(1)** intelligent and educated, are **(2)** to commit errors of judgement in the casting of votes. The best men may thus **(3)** to get elected. Elections are usually a **(4)** of propaganda. Another criticism of democracy is that it is wanting **(5)** efficiency.

Q4) (a) kind (b) process (c) matter (d) result

Ans. (c)

Democracy has its dangers, the greatest of which is that it may be the rule of ignorance. Citizens, who are not **(1)** intelligent and educated, are **(2)** to commit errors of judgement in the casting of votes. The best men may thus **(3)** to get elected. Elections are usually a **(4)** of propaganda. Another criticism of democracy is that it is wanting **(5)** efficiency.

Q5) (a) of (b) for (c) at (d) in

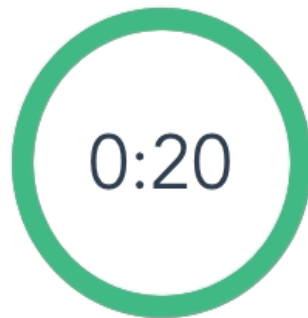

Democracy has its dangers, the greatest of which is that it may be the rule of ignorance. Citizens, who are not **(1)** intelligent and educated, are **(2)** to commit errors of judgement in the casting of votes. The best men may thus **(3)** to get elected. Elections are usually a **(4)** of propaganda. Another criticism of democracy is that it is wanting **(5)** efficiency.

Q5) (a) of (b) for (c) at (d) in

Ans. (d)

DIRECTIONS

In the following question, out of the four alternatives, select the alternative which is the best substitute of the given phrase.

Q. A government by the nobles

(a) aristocracy

(b) calculate

(c) adroit

(d) pantheism

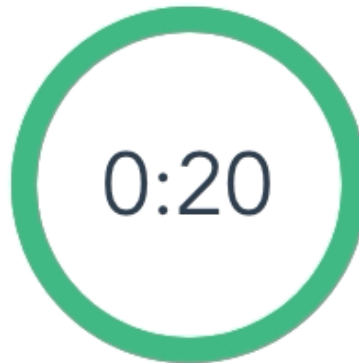

Q. A government by the nobles

(a) aristocracy

(b) calculate

(c) adroit

(d) pantheism

Ans. (a)

Q. A sentence whose meaning is unclear

(a) momentous

(b) sincere

(c) ambiguous

(d) panache

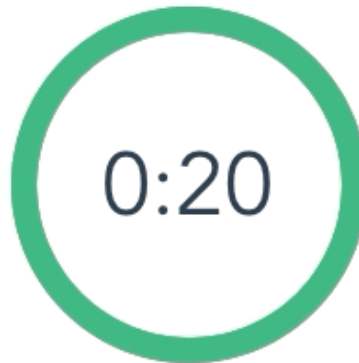

Q. A sentence whose meaning is unclear

(a) momentous

(b) sincere

(c) ambiguous

(d) panache

Ans. (c)

Q. A study of ancient things

(a) physiology

(b) archaeology

(c) ethnology

(d) zoology

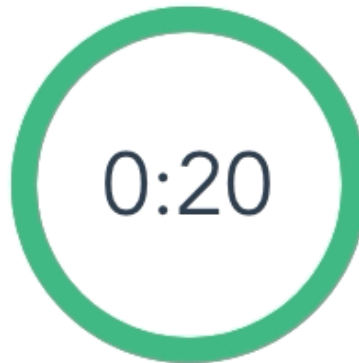

Q. A study of ancient things

(a) physiology

(b) archaeology

(c) ethnology

(d) zoology

Ans. (b)

Q. One who has long experience

(a) expert

(b) novice

(c) practitioner

(d) veteran

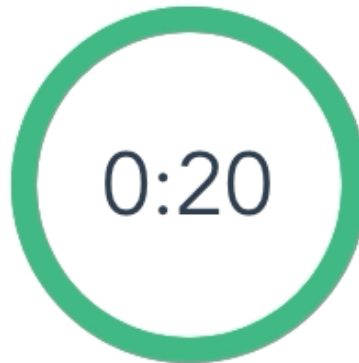

Q. One who has long experience

(a) expert

(b) novice

(c) practitioner

(d) veteran

Ans. (d)

Q. A person who deserves all praise

(a) despicable

(b) detestable

(c) laudable

(d) lovable

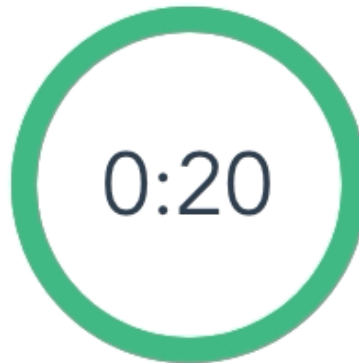

Q. A person who deserves all praise

(a) despicable

(b) detestable

(c) laudable

(d) lovable

Ans. (c)





SSB Interview Online Coaching 2025

SSB Interview: 🎓 Live Classes 🎥 In-Depth Lectures 📖 SSB Notes 🔥 Mock Tests 📅 Current Affairs ✂️ Defence Current Affairs.

★★★★★ 5.0 (253)

Content 18

🔍 FILTER BY TYPE ▾

-  **SSB Live Batch January 2025**
Course • 969 Lessons 11 Trials
-  **SSB Live Batch February 2025 – Enroll Now**
Course • 1 Lessons 1 Trial
-  **Basics of SSB Interview**
Course • 68 Lessons
-  **OIR Test – Verbal Reasoning – Part 1**
Course • 618 Lessons
-  **OIR Test – Verbal Reasoning – Part 2**
Course • 401 Lessons



🕒 365 Days validity

₹ 6,999 ~~₹ 9,999~~ 30% OFF

[BUY BUNDLE](#)

[START A FREE TRIAL](#)

What's included

📁 18 Courses

Other Pricing Plans

Validity 30 Days

30 Days Validity

[Details](#)

₹4,999 ~~₹5,999~~ 17% off

[BUY NOW](#)





AFCAT Exam Online Coaching 2025

AFCAT 2025: Live Classes In-Depth Lectures Study Notes Mock Tests Current Affairs Defence Current Affairs.

★★★★★ 5.0 (147)

Content 22

Search in bundle

-  **AFCAT 1 2025 Live Batch - 2**
Course • 331 Lessons
-  **AFCAT 2 2024 Exam Answerkey | 09 - 11 Aug 2024 | Shift 1 & 2**
Course • 228 Lessons 1 Trial
-  **AFCAT 1 2024 Live Batch - 2**
Course • 148 Lessons 2 Trials
-  **AFCAT 1 2024 Live Batch - 1**
Course • 315 Lessons 1 Trial
-  **AFCAT Exam Overview**
Course • 26 Lessons



180 Days validity

₹ 4,999 ~~₹ 5,999~~ 17% OFF

What's included

22 Courses

Other Pricing Plans

Validity 12 Months Details
 365 Days Validity
 ₹5,999 ~~₹7,999~~ 25% off

Bundles 13

[View All](#)



Sainik School Exam Course for Class 6

5 Courses

₹ 2,999 ~~₹ 5,999~~ 50% OFF



SSB Interview Online Coaching 2025

18 Courses

₹ 6,999 ~~₹ 9,999~~ 30% OFF

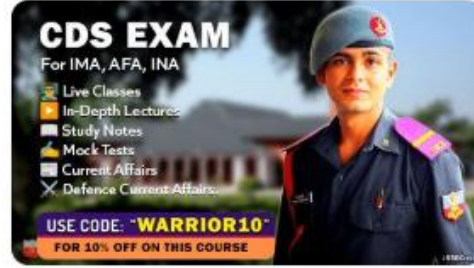

CDS Exam Online Coaching 2025

23 Courses

₹ 4,999 ~~₹ 5,999~~ 17% OFF

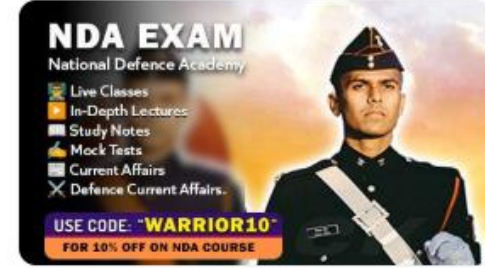

NDA Exam Online Coaching 2025

23 Courses

₹ 4,999 ~~₹ 5,999~~ 17% OFF

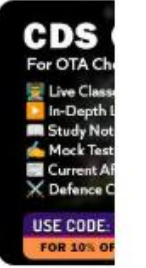

CDS Exam Online Coaching 2025

22 Courses

₹ 4,499

Test series 07

[View All](#)

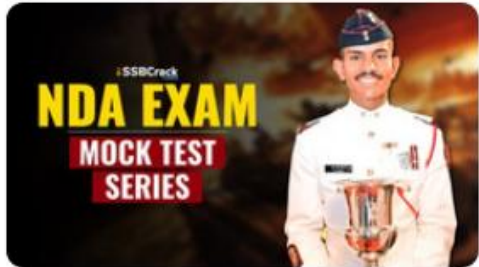

NDA Mock Test Series 2025

40 Tests

₹ 499 ~~₹ 999~~ 50% OFF



AFCAT Mock Test Series 2025

20 Tests

₹ 499 ~~₹ 999~~ 50% OFF



CDS Exam Mock Test Series 2025

30 Tests

₹ 499 ~~₹ 999~~ 50% OFF



CDS OTA Exam Mock Test Series 2025

20 Tests

₹ 499 ~~₹ 999~~ 50% OFF



MNS Mock Test Series 2025

20 Tests

₹ 499

India's Most Popular Portal for Defence Exam Preparation

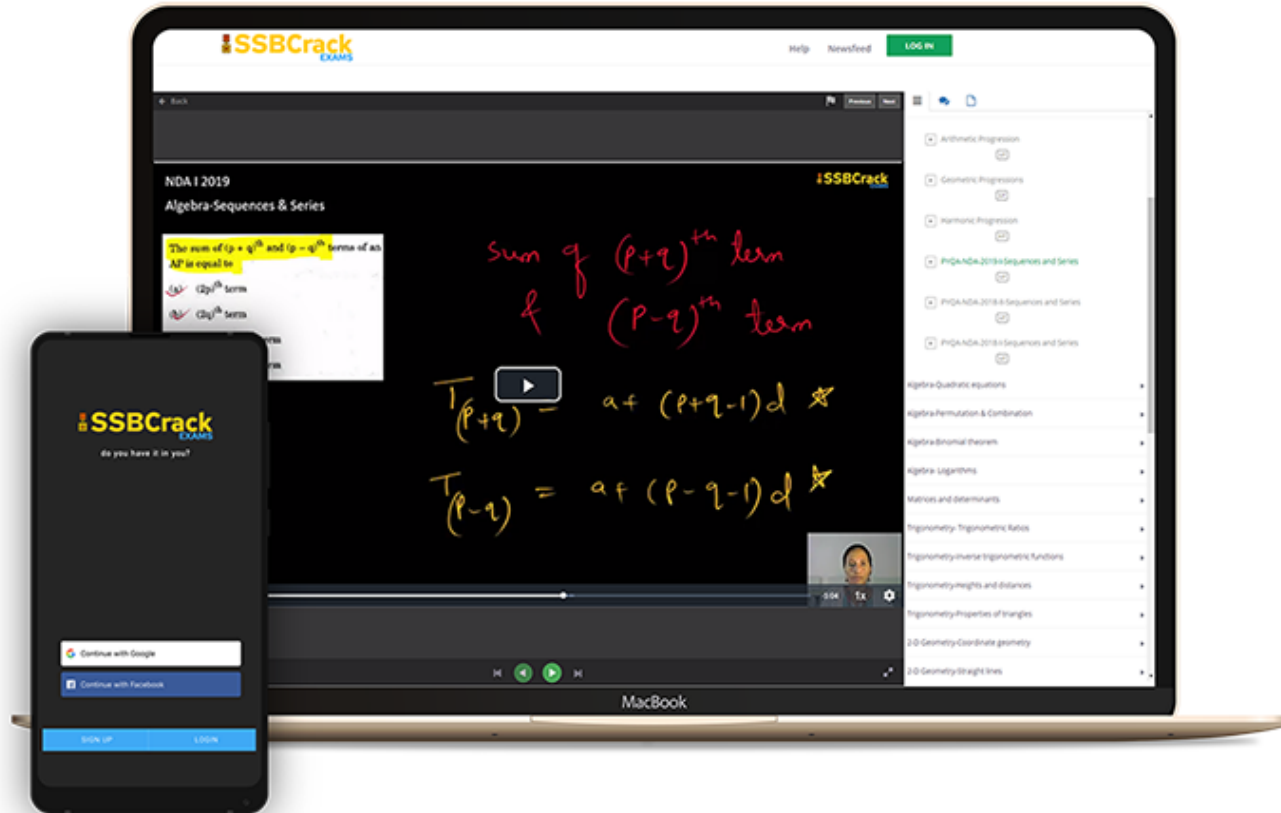

www.ssbcrackexams.com

CODE: WARRIOR10

get an extra **10%** off on all courses





AFCAT 1 2025

MAHA MARATHON #1



COMPLETE REVISION

19 FEB 2025

12 PM TO 04 PM



LIVE CLASS



AFCAT 1 2025

MAHA MARATHON

19 TO 21 FEB 2025

12 PM TO 01 PM

MATHS - NAVJYOTI SIR

01 PM TO 02 PM

ENGLISH - ANURADHA MA'AM

02 PM TO 03 PM

REASONING - RUBY MA'AM

03 PM TO 04 PM

STATIC GK - DIVYANSHU SIR

 CALL US: 080-69185400

GET IT ON
Google Play

DOWNLOAD
THE APP NOW



Painter Who Are Neither Chinese Nor Musician

A. b

B. c

C. f

D. g

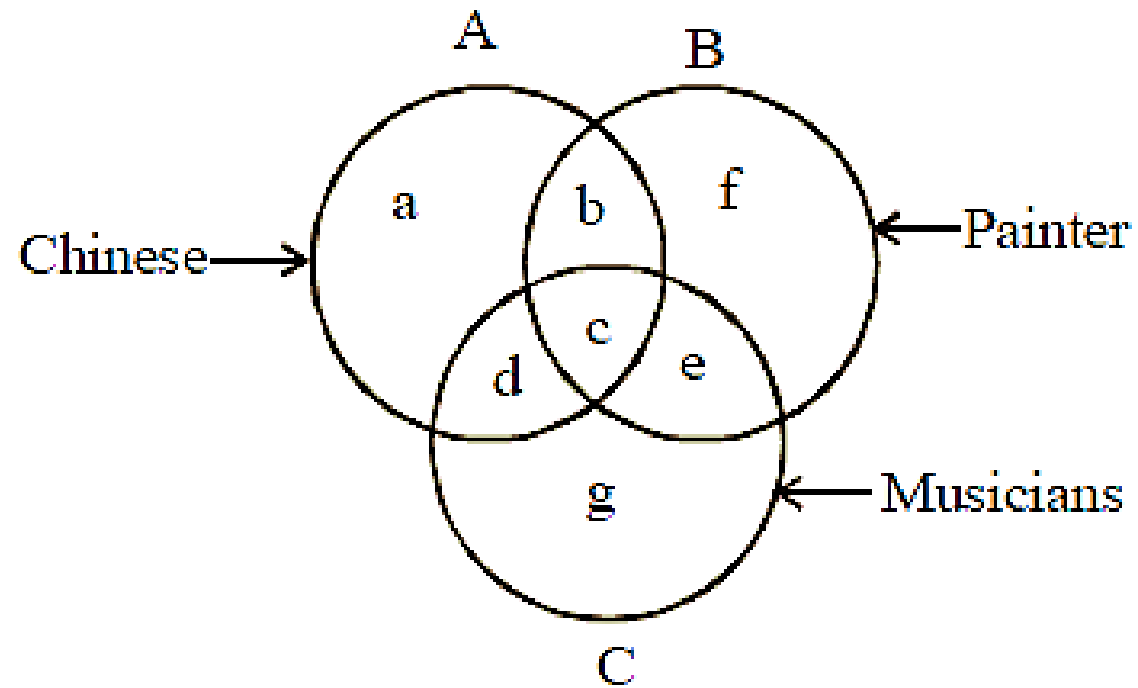

Painter Who Are Neither Chinese Nor Musician

A. b

B. c

C. f

D. g

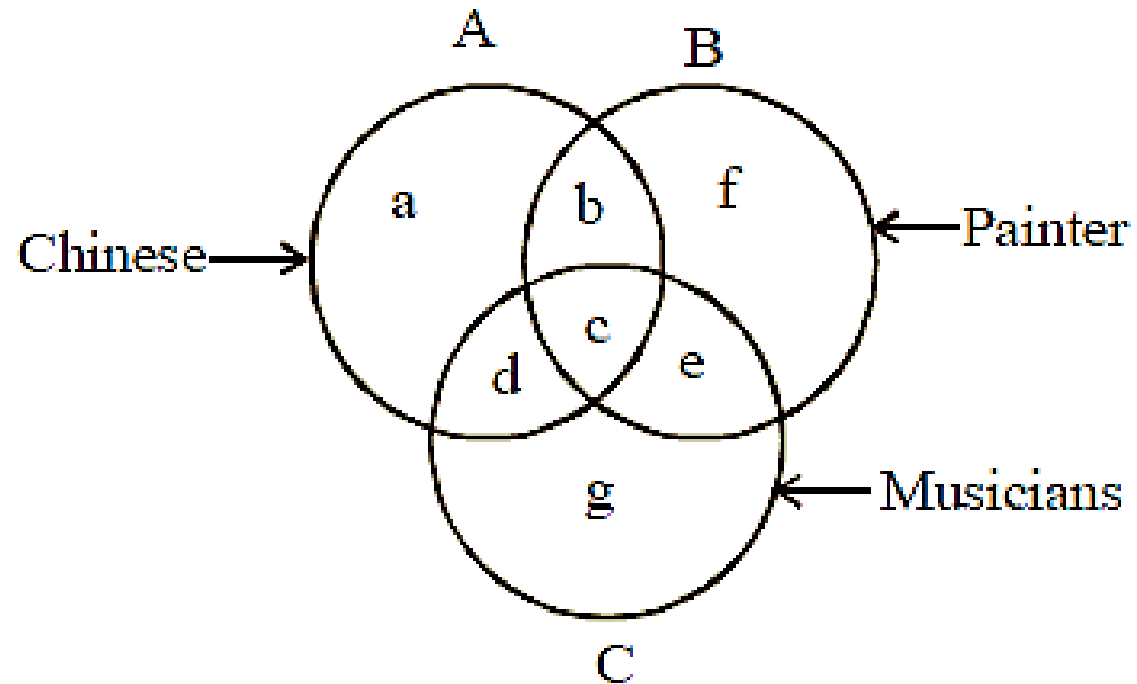

Identify the diagram that best represents the relationship among the given classes. Music Instrument, Piano, Guiter

(a)

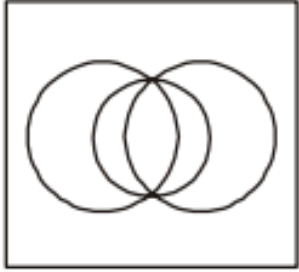

(b)

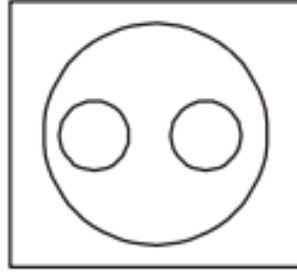

(c)

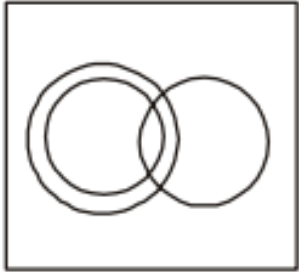

(d)

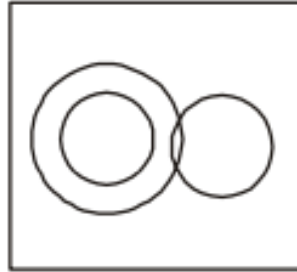

Identify the diagram that best represents the relationship among the given classes. Music Instrument, Piano, Guiter

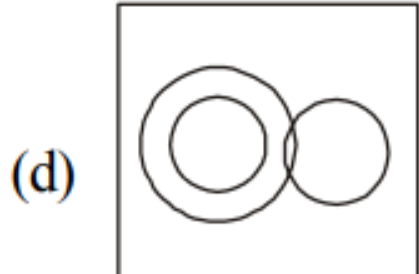
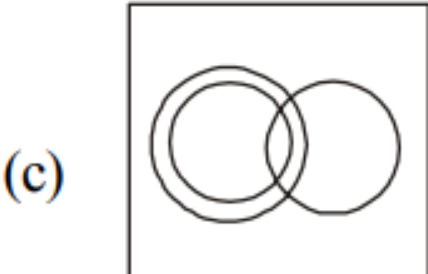
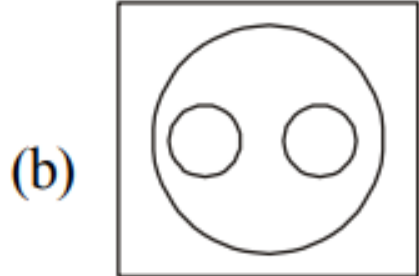
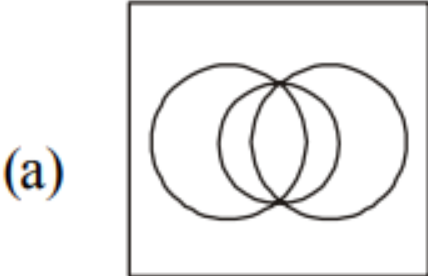

Ans: (b)

Which Of The Following Diagrams Indicates The Best Relation Between Travelers, Train And Bus

A.

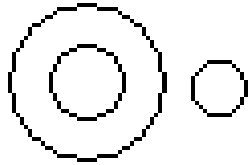

B.

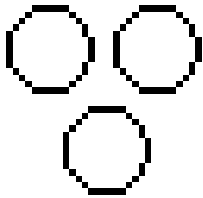

C.

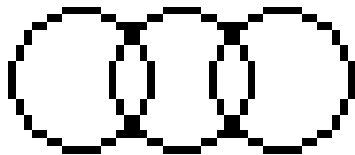

D.

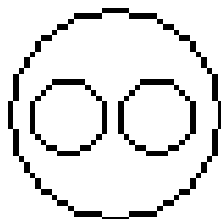

Which Of The Following Diagrams Indicates The Best Relation Between Travelers, Train And Bus

A.

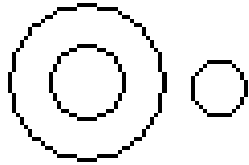

B.

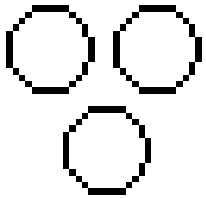

C.

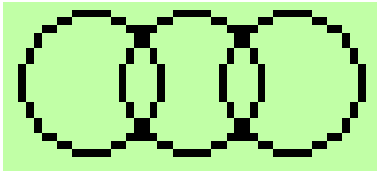

D.

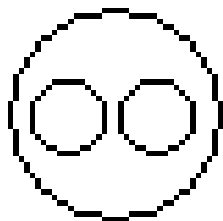

Which One Of The Following Venn Diagrams Represents The Best Relationship Between Snake, Lizard, Reptiles

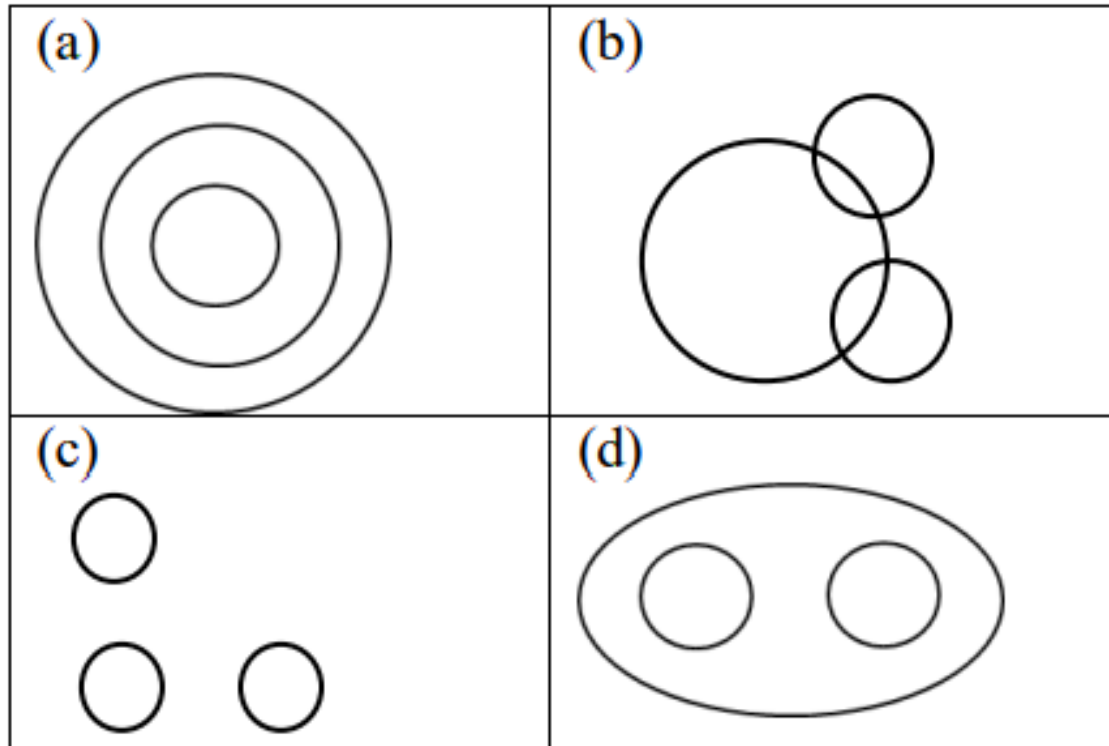

Which One Of The Following Venn Diagrams Represents The Best Relationship Between Snake, Lizard, Reptiles

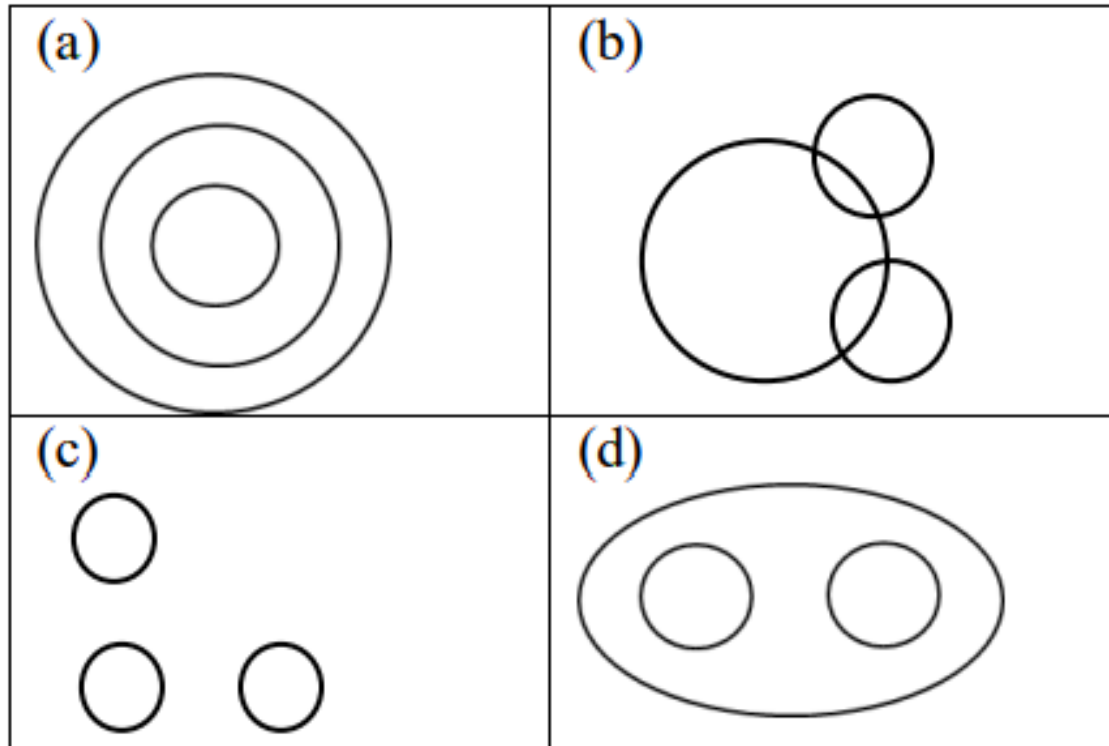

Ans. D

REASON : SFBTPO :: THINK : ?

A. SGHMJ

B. UIJOL

C. UHNKI

D. UJKPM

REASON : SFBTPO :: THINK : ?

A. SGHMJ

B. UIJOL

C. UHNKI

D. UJKPM

As

R $\xrightarrow{+1}$ S

E $\xrightarrow{+1}$ F

A $\xrightarrow{+1}$ B

S $\xrightarrow{+1}$ T

O $\xrightarrow{+1}$ P

N $\xrightarrow{+1}$ O

Similarly

T $\xrightarrow{+1}$ U

H $\xrightarrow{+1}$ I

I $\xrightarrow{+1}$ J

N $\xrightarrow{+1}$ O

K $\xrightarrow{+1}$ L

NATION : ANTINO :: HUNGRY : ?

A. HNUGRY

B. UHNGYR

C. YRNGUH

D. UNHGYR

NATION : ANTINO :: HUNGRY : ?

A. HNUGRY

B. UHNGYR

C. YRNGUH

D. UNHGYR

As



T → T

I → I

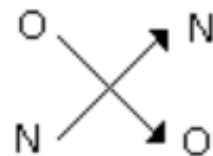

Similarly

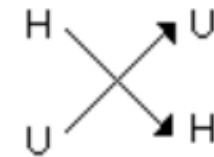

N → N

G → G

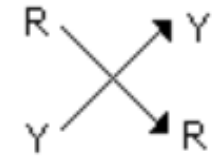

Eye : Myopia :: Teeth : ?

- A. Pyorrhoea
- B. Cataract
- C. Trachoma
- D. Eczema

Eye : Myopia :: Teeth : ?

A. Pyorrhoea

B. Cataract

C. Trachoma

D. Eczema

In An Organization Of Pollution Control Board, Engineers Are Represented By A Circle, Legal Experts By A Square And Environmentalist By A Triangle. Who Is Most Represented In The Board As Shown In The Following Figure

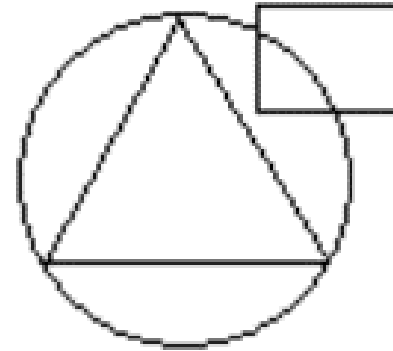

- A. Environmentalists
- B. Legal Experts
- C. Engineers with legal background
- D. Environmentalists with Engineering background

In An Organization Of Pollution Control Board, Engineers Are Represented By A Circle, Legal Experts By A Square And Environmentalist By A Triangle. Who Is Most Represented In The Board As Shown In The Following Figure

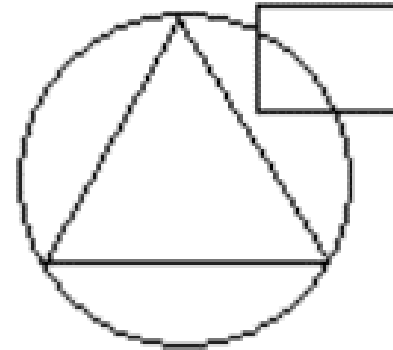

- A. Environmentalists
- B. Legal Experts
- C. Engineers with legal background
- D. Environmentalists with Engineering background**

In The Following Figure Triangle Represents 'Girls', Square Players And Circle-coach. Which Part Of The Diagram Represents The Girls Who Are Player But Not Coach

A. P

B. Q

C. R

D. S

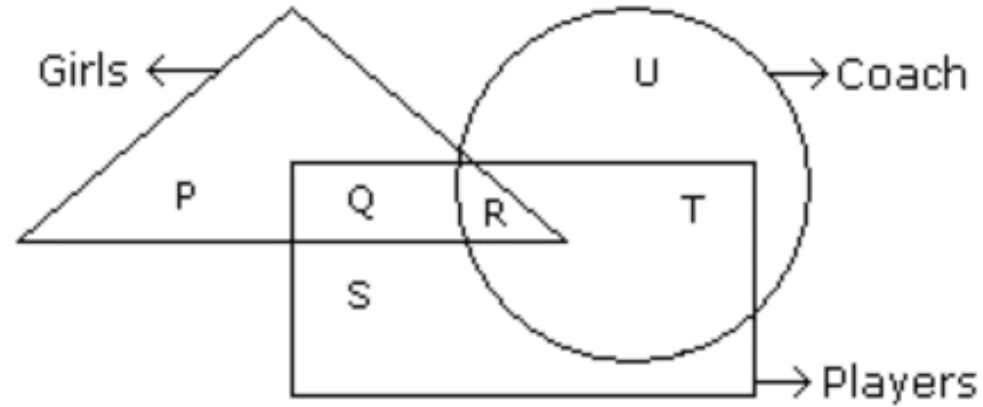

In The Following Figure Triangle Represents 'Girls', Square Players And Circle-coach. Which Part Of The Diagram Represents The Girls Who Are Player But Not Coach

A. P

B. Q

C. R

D. S

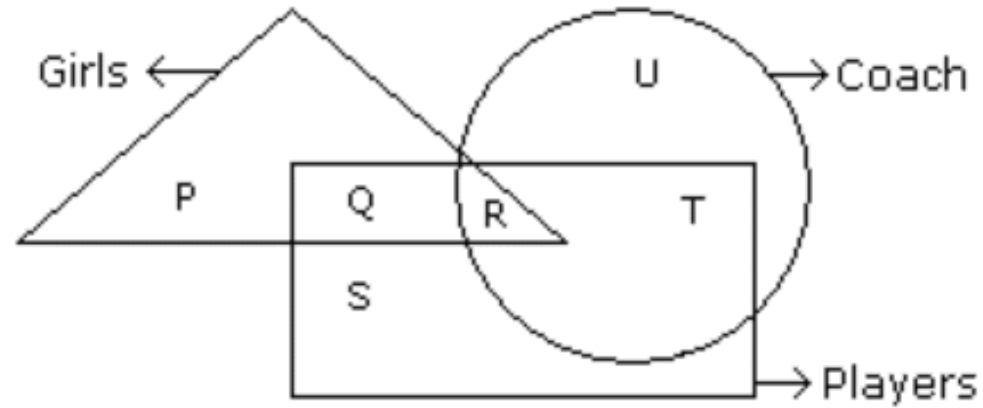

The Diagram Given Below Represents Those Students Who Play Cricket, Football And Kabaddi

A. $P + Q + R$

B. $V + T$

C. $S + T + V$

D. S

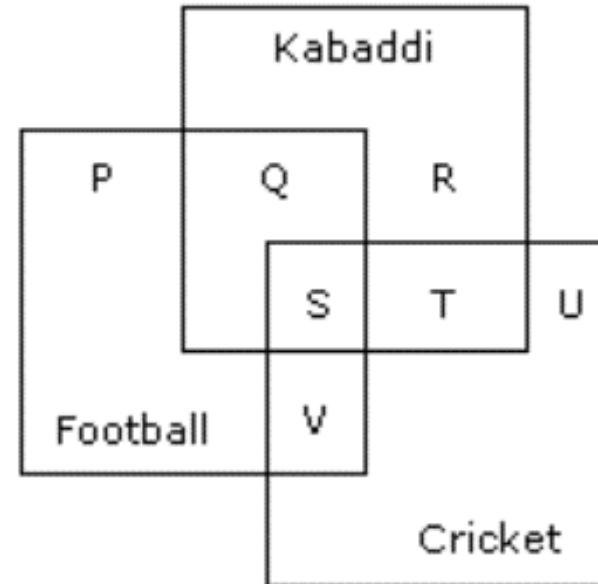

The Diagram Given Below Represents Those Students Who Play Cricket, Football And Kabaddi

A. $P + Q + R$

B. $V + T$

C. $S + T + V$

D. **S**

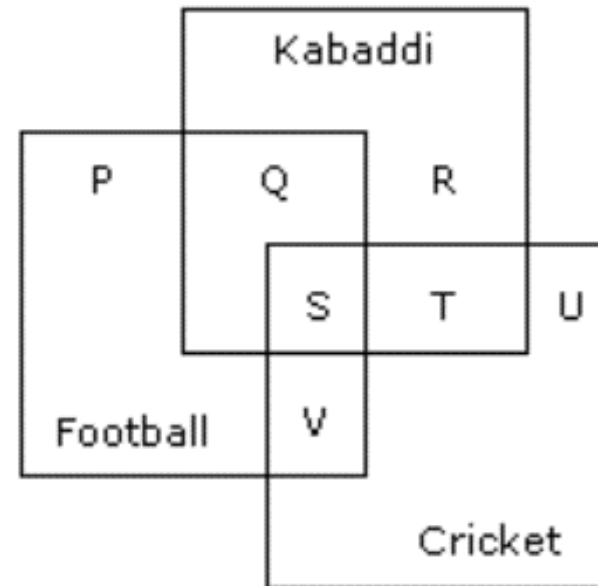

Q) In the following figure, rectangle represents Opticians, circle represents Art critics, triangle represents Riders and square represents Boxes. Which set of letters represents Art critics who are not Riders?

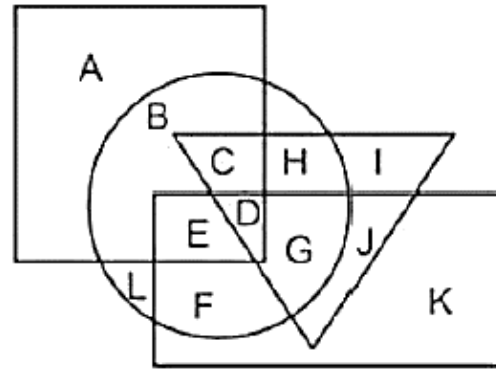

(a) BLEF

(b) IJ

(c) CHDG

(d) EDGJ

Q) In the following figure, rectangle represents Opticians, circle represents Art critics, triangle represents Riders and square represents Boxes. Which set of letters represents Art critics who are not Riders?

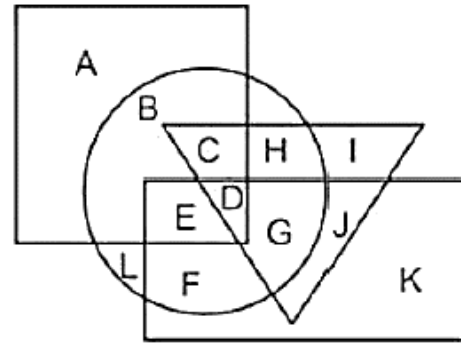

- (a) BLEF
- (c) CHDG

- (b) IJ
- (d) EDGJ

Ans: (a)

Q)

Which one of the following diagram represents the correct relationship among Professor, Male and Female.

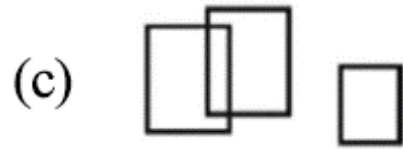
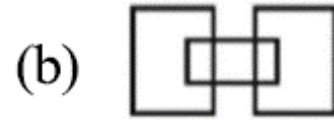
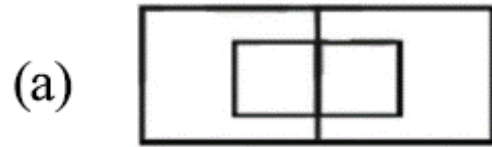

Q)

Which one of the following diagram represents the correct relationship among Professor, Male and Female.

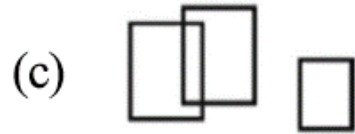
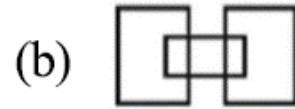
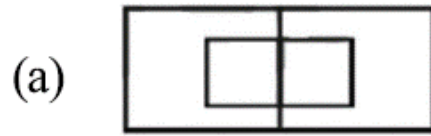

Ans: (a)

Tiger : Forest :: Otter : ?

- A. Cage
- B. Sky
- C. Nest
- D. Water

Tiger : Forest :: Otter : ?

- A. Cage
- B. Sky
- C. Nest
- D. Water**

Poles : Magnet :: ? : Battery

- A. Cells
- B. Power
- C. Terminals
- D. Energy

Poles : Magnet :: ? : Battery

A. Cells

B. Power

C. Terminals

D. Energy

Cassock : Priest :: ? : Graduate

A. Cap

B. Tie

C. Coat

D. Gown

Cassock : Priest :: ? : Graduate

- A. Cap
- B. Tie
- C. Coat
- D. Gown**



MO : 13 11 :: HJ : ?

A. 19 17

B. 18 16

C. 8 10

D. 16 18

MO : 13 11 :: HJ : ?

A. 19 17

B. 18 16

C. 8 10

D. 16 18

MXN : 13 x 14 :: FXR : ?

A. 14 x 15

B. 5 x 17

C. 6 x 18

D. 7 x 19

MXN : 13 x 14 :: FXR : ?

A. 14 x 15

B. 5 x 17

C. 6 x 18

D. 7 x 19

BEGK : ADFJ :: PSVY : ?

A. ROUX

B. ORUX

C. LQUT

D. LOQT

BEGK : ADFJ :: PSVY : ?

A. ROUX

B. ORUX

C. LQUT

D. LOQT

As

B $\xrightarrow{-1}$ A

E $\xrightarrow{-1}$ D

G $\xrightarrow{-1}$ F

K $\xrightarrow{-1}$ J

Similarly

P $\xrightarrow{-1}$ O

S $\xrightarrow{-1}$ R

V $\xrightarrow{-1}$ U

Y $\xrightarrow{-1}$ X

Q) Choose the correct Venn diagram which best illustrates the relationship among Hockey, Cricket, Games.

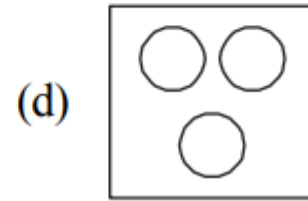
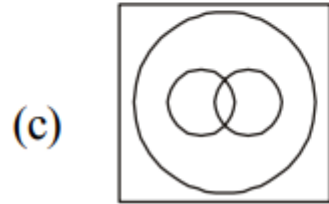
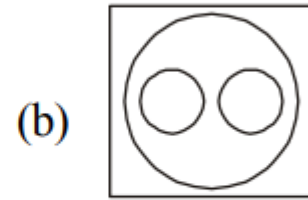
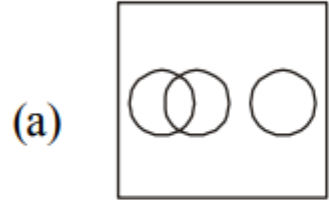

Q) Choose the correct Venn diagram which best illustrates the relationship among Hockey, Cricket, Games.

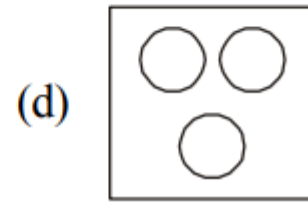
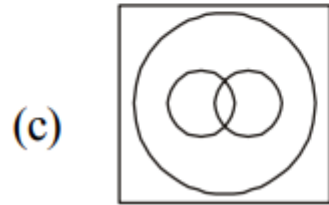
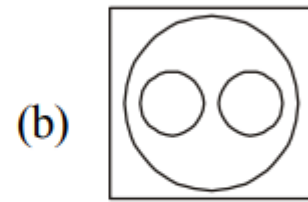
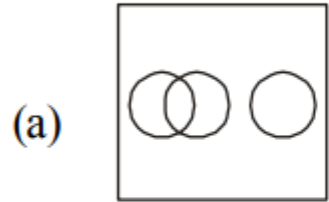

Ans: (b)

Q) In the given figure, How many water are either tap or shower?

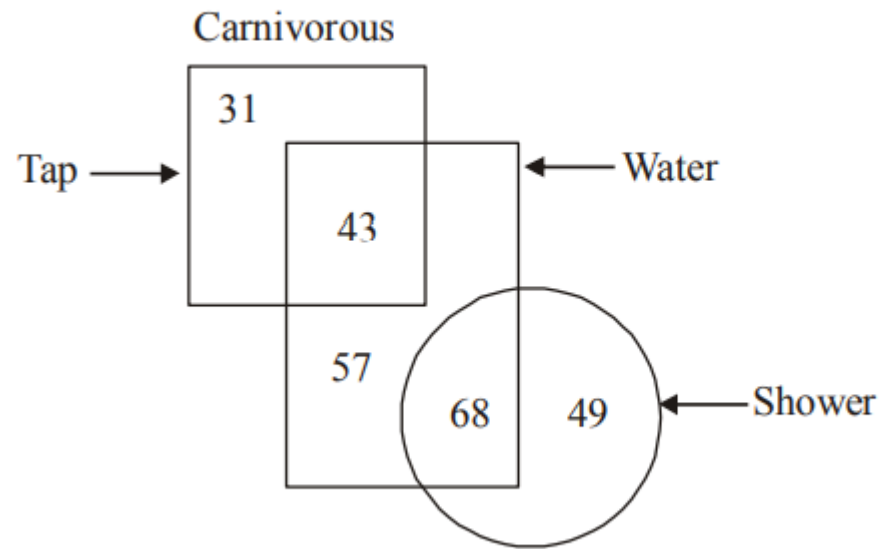

(a) 168

(b) 111

(c) 125

(d) 108

Q) In the given figure, How many water are either tap or shower?

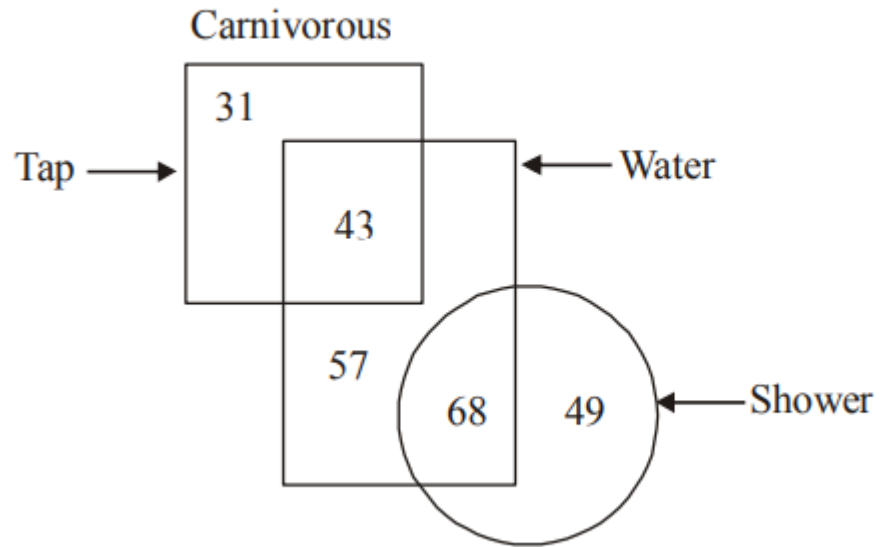

- (a) 168 (b) 111 (c) 125 (d) 108

Ans: (b)

Which Of Following Diagram Indicates Best Relation Between Travellers, Train And Bus

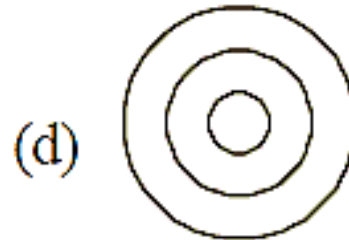
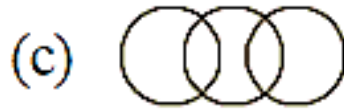
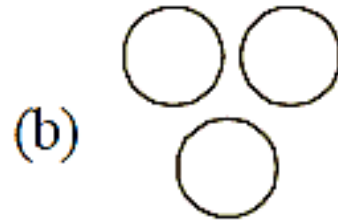
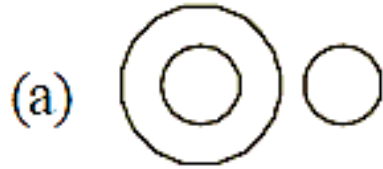

Which Of Following Diagram Indicates Best Relation Between Travellers, Train And Bus

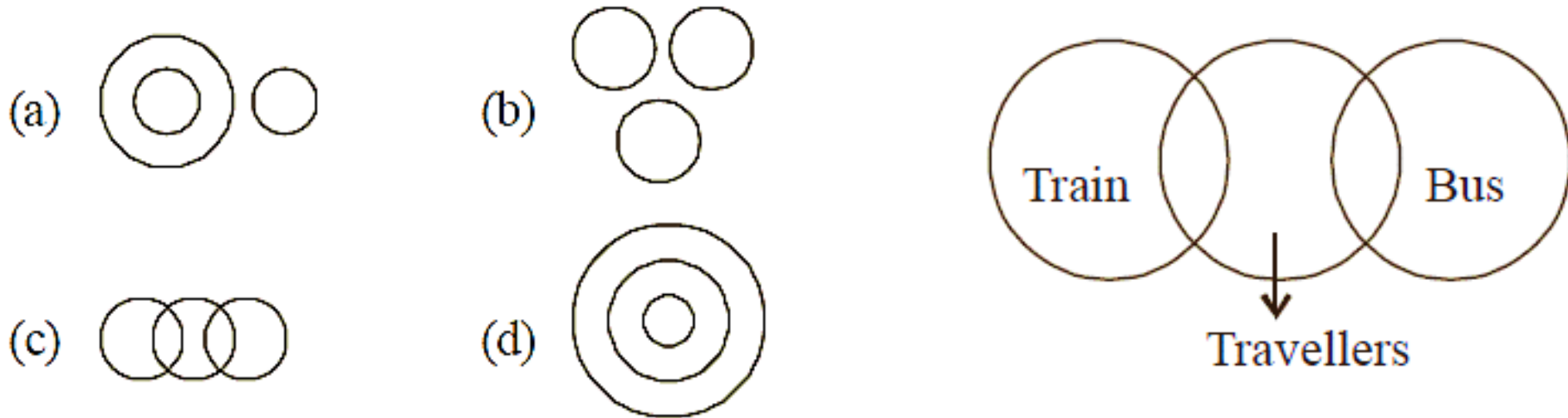

ANSWER – C

Identify Diagram That Best Represents Relationship Among Given Classes. Earth, Saturn, Planet, Star

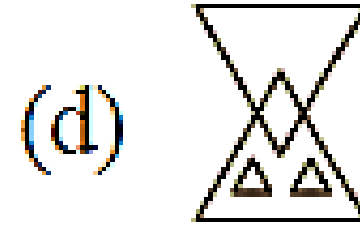
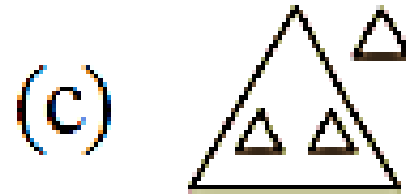
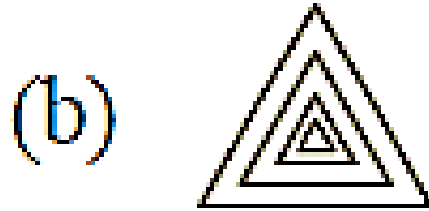
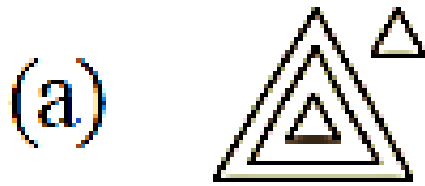

Identify Diagram That Best Represents Relationship Among Given Classes. Earth, Saturn, Planet, Star

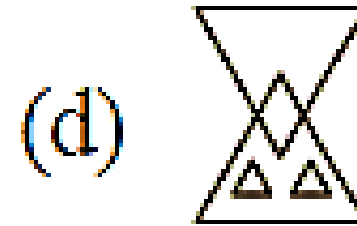
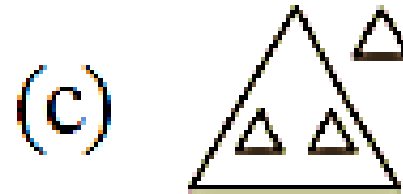
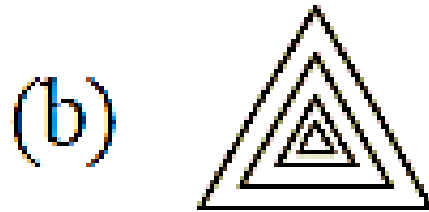
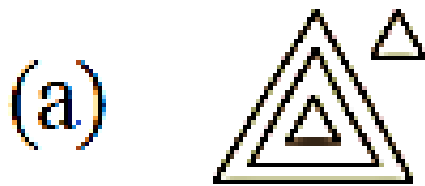

ANSWER - C

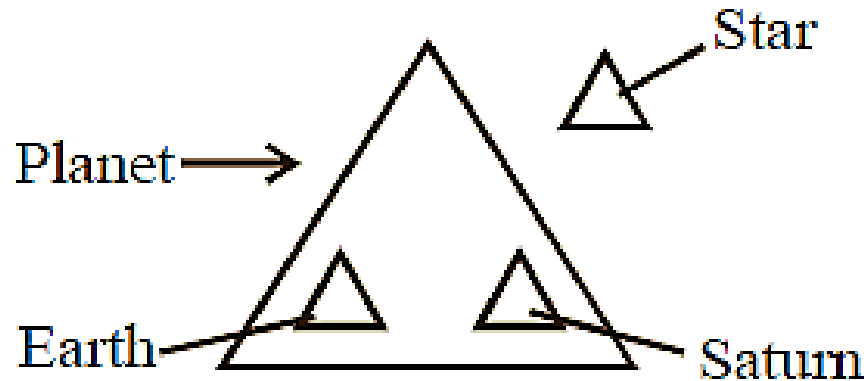

Q)

Which one of the following diagram represents the correct relationship among

Brain, Cerebrum, Liver and Human body.

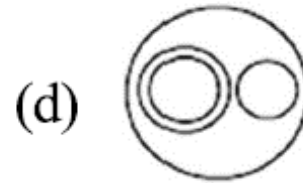
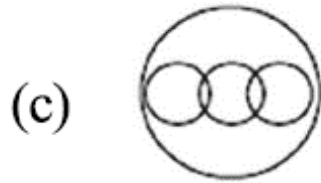
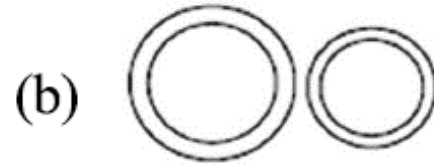
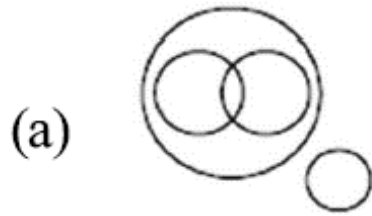

Q)

Which one of the following diagram represents the correct relationship among

Brain, Cerebrum, Liver and Human body.

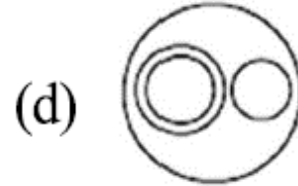
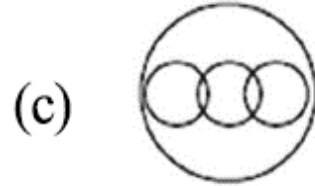
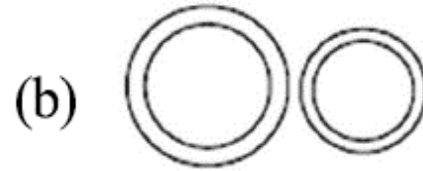
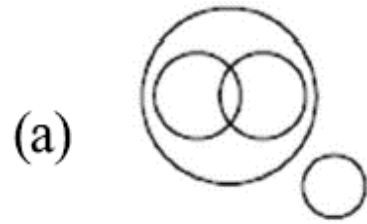

Ans: (d)

Q) Student of law, Student of science, Men

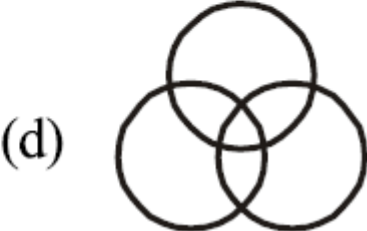
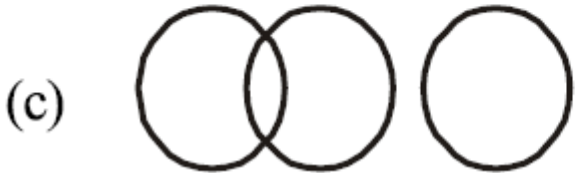
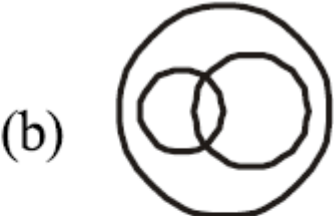
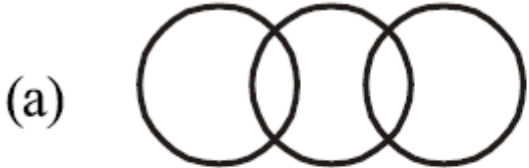

Q) Student of law, Student of science, Men

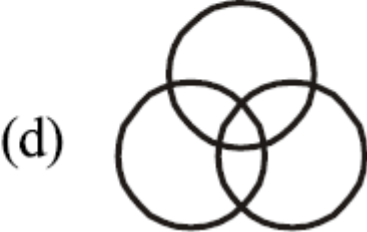
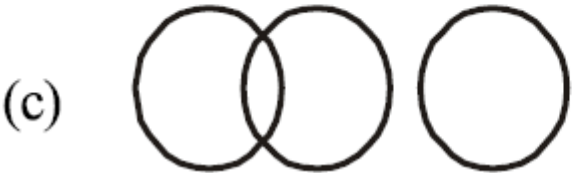
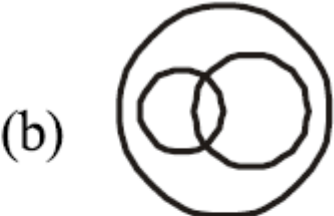
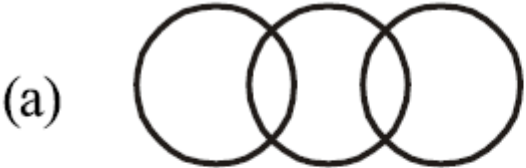

Ans: (a)

Q)

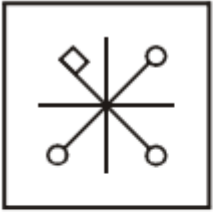

:

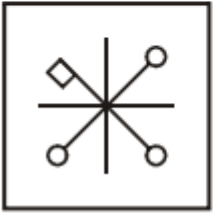
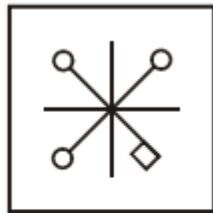

:



(a)

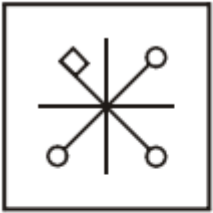

(b)

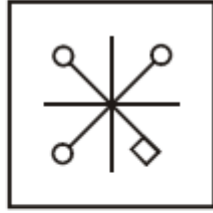

(c)

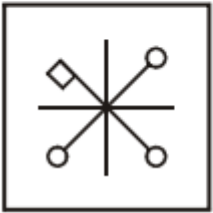

(d)

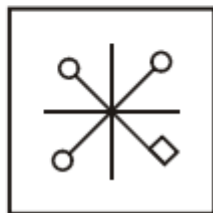

Q)

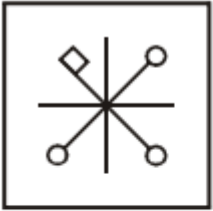

:

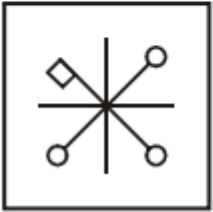
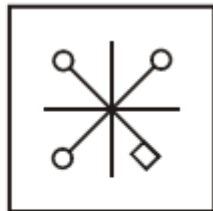

:



(a)

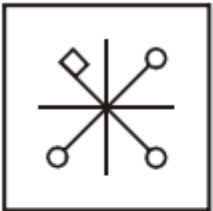

(b)

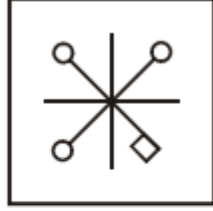

(c)

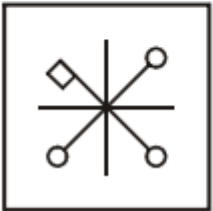

(d)

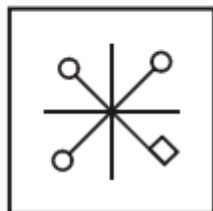

Ans: (d)

Q)

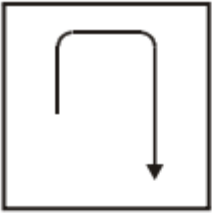

:

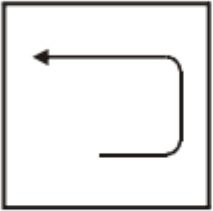
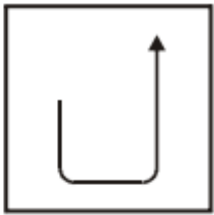

:



(a)

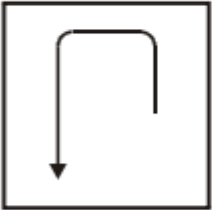

(b)

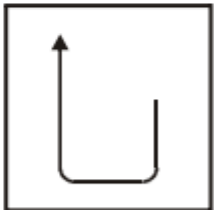

(c)

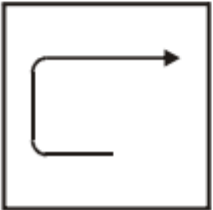

(d)

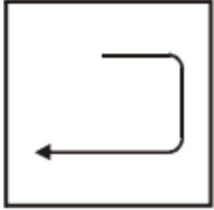

Q)

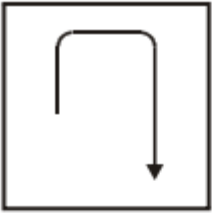

:

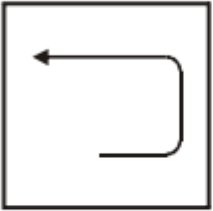
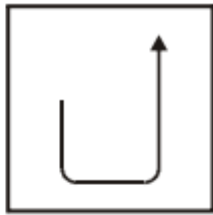

:



(a)

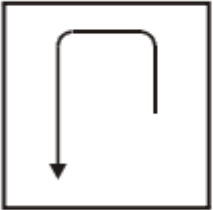

(b)

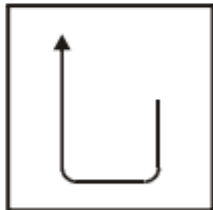

(c)

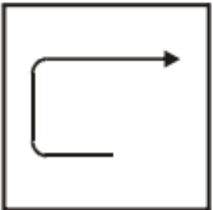

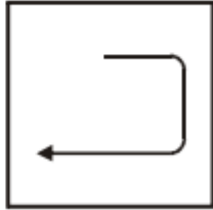

(d)

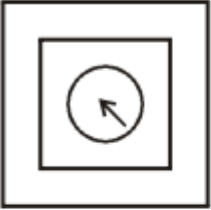
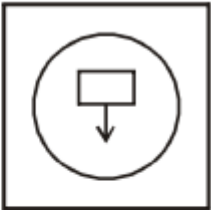

Ans: (d)

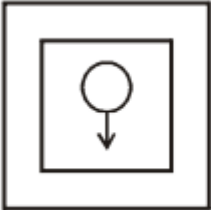
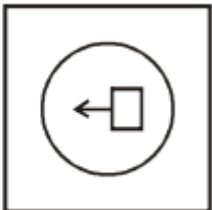

Q)  :  ::

 :  ::

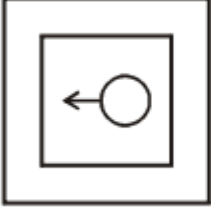
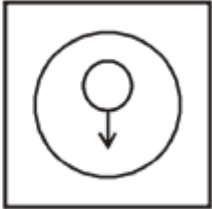

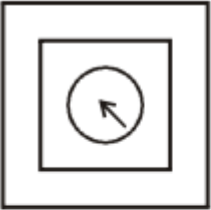
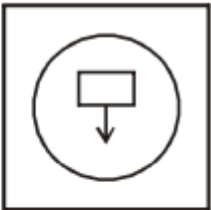
(a)  (b) 

(c)  (d) 

Q)  :  ::

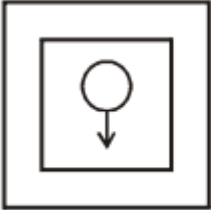
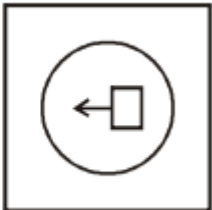
 :  ::

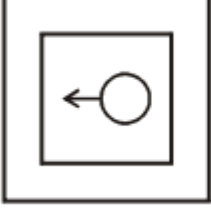
(a)  (b) 

(c)  (d) 

Ans: (a)

Problem Figures

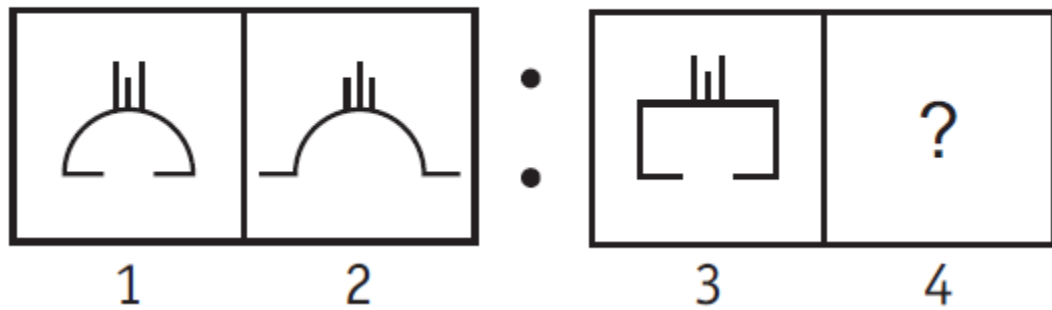

Answer Figures

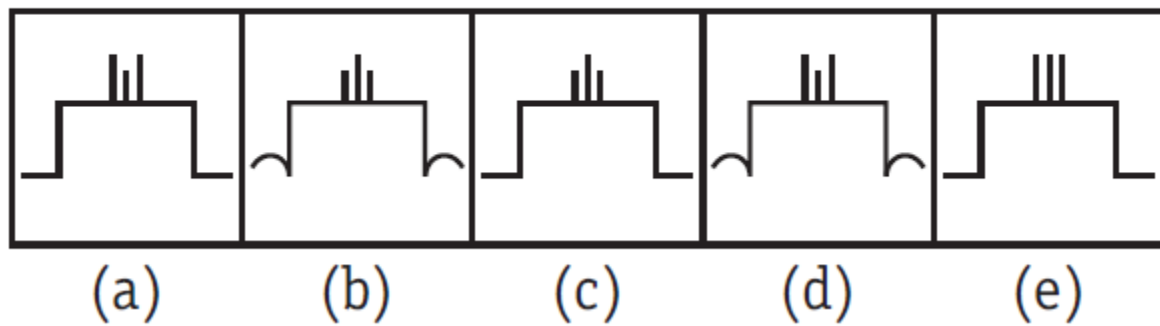

Problem Figures

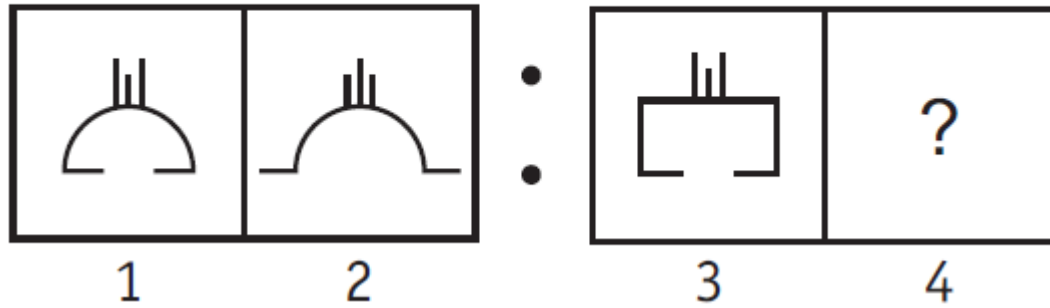

Answer Figures

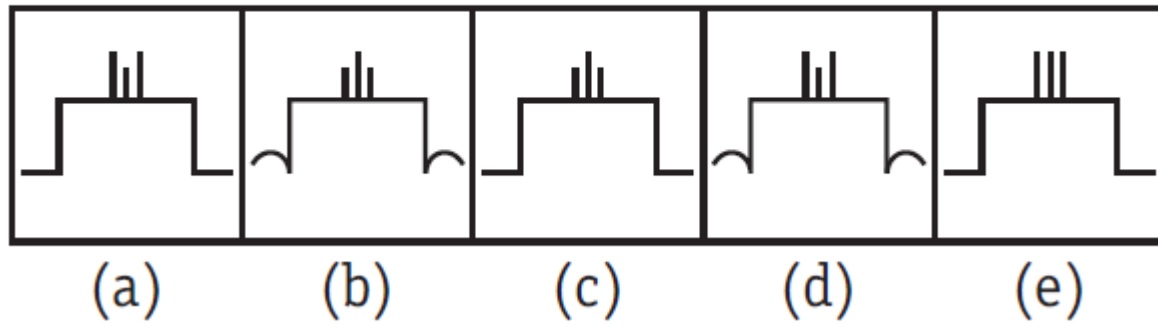

Ans: (c)

Q) Question Figure:

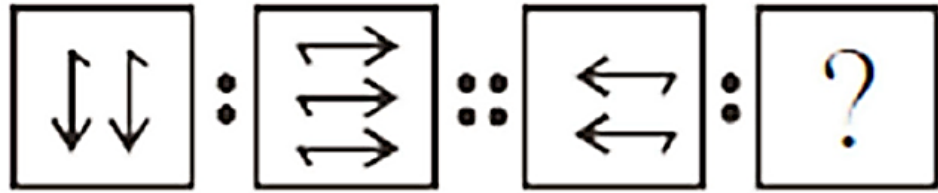

Answer Figure:

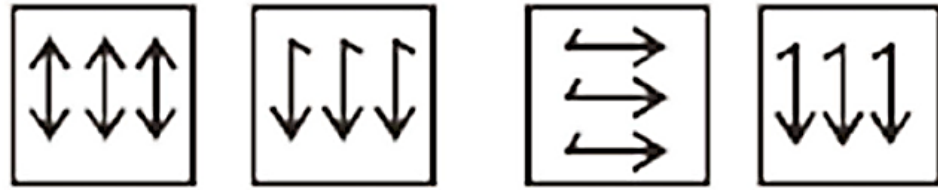

(a)

(b)

(c)

(d)

Q) Question Figure:

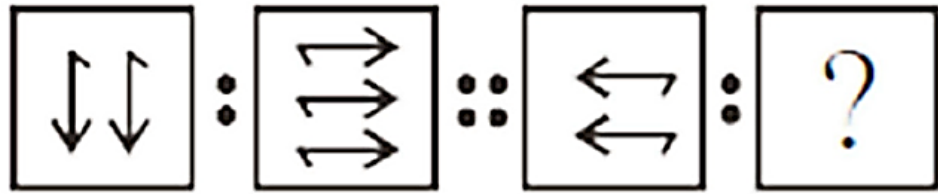

Answer Figure:

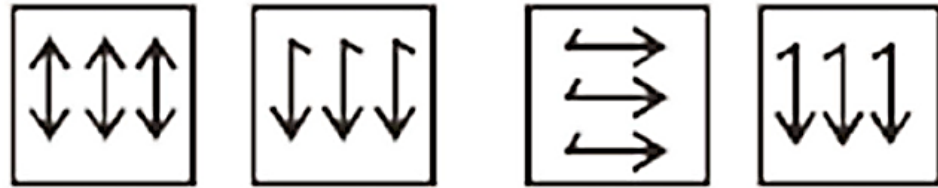

(a)

(b)

(c)

(d)

Ans: (d)

Q)

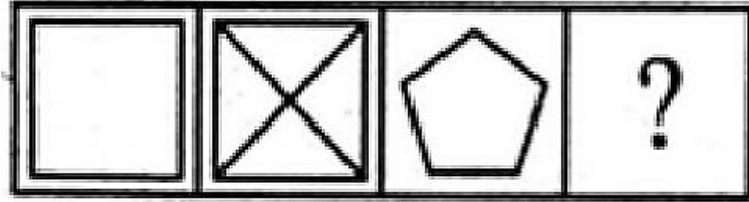

(1)

(2)

(3)

(4)

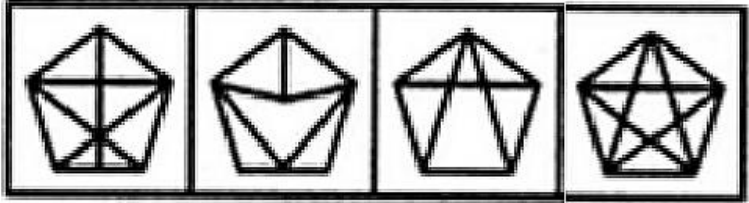

(a)

(b)

(c)

(d)

Q)

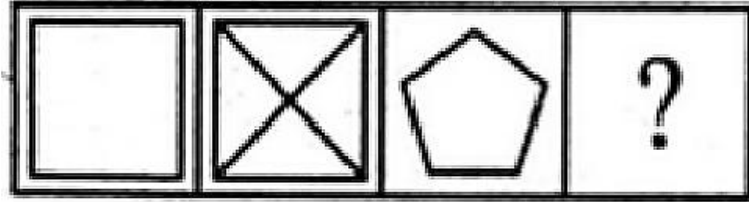

(1)

(2)

(3)

(4)

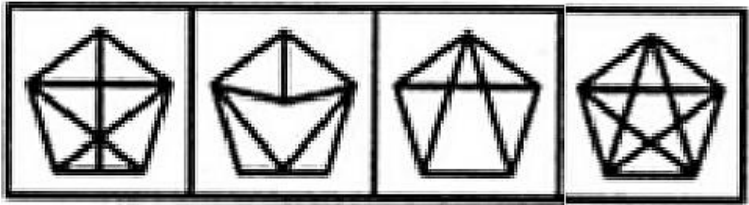

(a)

(b)

(c)

(d)

Ans: (d)

Q) The following diagram represents the students who are singers, dancers and poets.

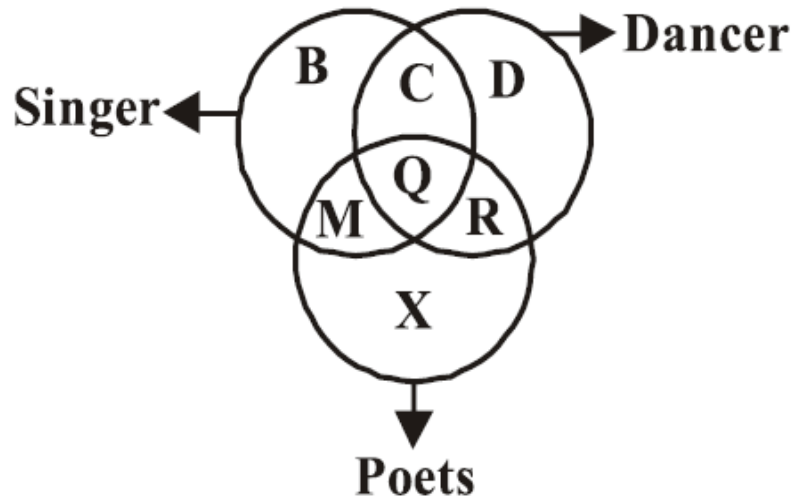

Study the diagram and identify the region which represents the students who are both poets and singers but not dancers.

- | | |
|-----------------|-------------|
| (a) $B + C + D$ | (b) M |
| (c) $Q + R$ | (d) $R + X$ |

Q) The following diagram represents the students who are singers, dancers and poets.

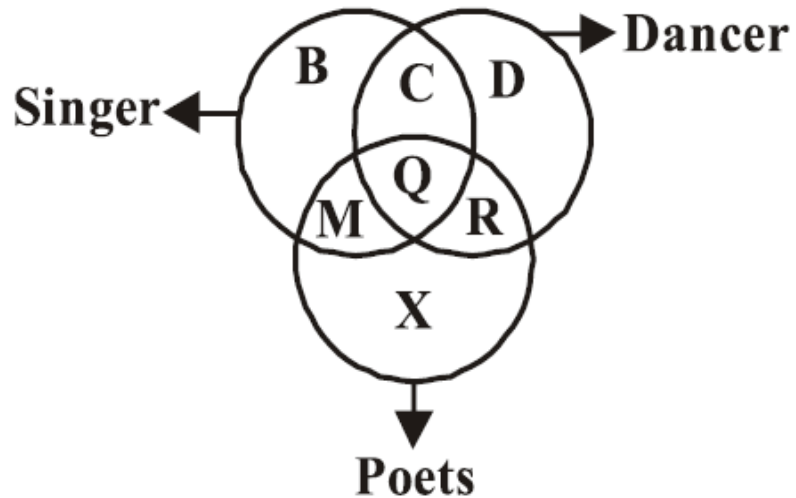

Study the diagram and identify the region which represents the students who are both poets and singers but not dancers.

- | | |
|-----------------|-------------|
| (a) $B + C + D$ | (b) M |
| (c) $Q + R$ | (d) $R + X$ |

Ans: (b)





AFCAT Exam Online Coaching 2025

AFCAT 2025: Live Classes In-Depth Lectures Study Notes Mock Tests Current Affairs Defence Current Affairs.

★★★★★ 5.0 (147)

Content 22

Search in bundle

-  AFCAT 1 2025 Live Batch - 2
Course • 331 Lessons
-  AFCAT 2 2024 Exam Answerkey | 09 - 11 Aug 2024 | Shift 1 & 2
Course • 228 Lessons 1 Trial
-  AFCAT 1 2024 Live Batch - 2
Course • 148 Lessons 2 Trials
-  AFCAT 1 2024 Live Batch - 1
Course • 315 Lessons 1 Trial
-  AFCAT Exam Overview
Course • 26 Lessons



180 Days validity

₹ 4,999 ~~₹ 5,999~~ 17% OFF

What's included

22 Courses

Other Pricing Plans

Validity 12 Months

365 Days Validity

[Details](#)

₹5,999 ~~₹7,999~~ 25% off

Bundles 13

[View All](#)



Sainik School Exam Course for Class 6

5 Courses

₹ 2,999 ~~₹ 5,999~~ 50% OFF



SSB Interview Online Coaching 2025

18 Courses

₹ 6,999 ~~₹ 9,999~~ 30% OFF

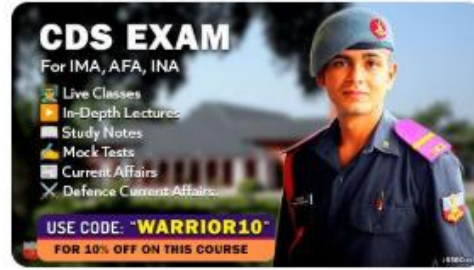

CDS Exam Online Coaching 2025

23 Courses

₹ 4,999 ~~₹ 5,999~~ 17% OFF

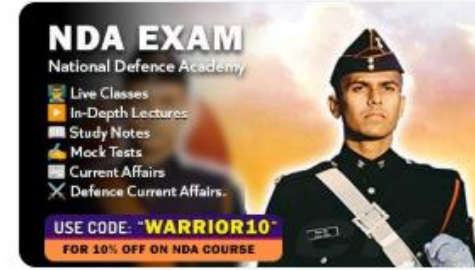

NDA Exam Online Coaching 2025

23 Courses

₹ 4,999 ~~₹ 5,999~~ 17% OFF

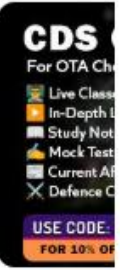

CDS Exam Online Coaching 2025

22 Courses

₹ 4,499

Test series 07

[View All](#)



NDA Mock Test Series 2025

40 Tests

₹ 499 ~~₹ 999~~ 50% OFF



AFCAT Mock Test Series 2025

20 Tests

₹ 499 ~~₹ 999~~ 50% OFF



CDS Exam Mock Test Series 2025

30 Tests

₹ 499 ~~₹ 999~~ 50% OFF



CDS OTA Exam Mock Test Series 2025

20 Tests

₹ 499 ~~₹ 999~~ 50% OFF



MNS Mock Test Series 2025

20 Tests

₹ 499

India's Most Popular Portal for Defence Exam Preparation

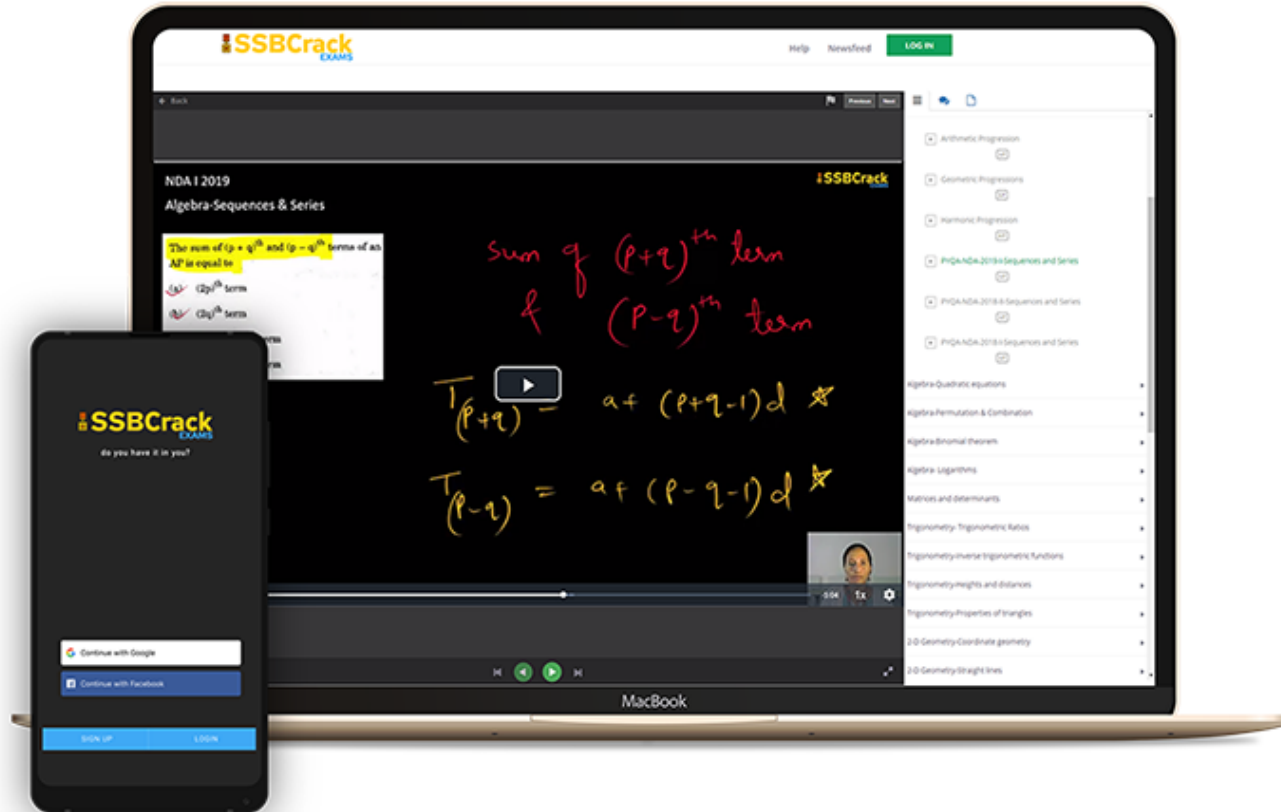
www.ssbcrackexams.com**CODE: WARRIOR10**get an extra **10%** off on all courses



AFCAT 1 2025

MAHA MARATHON #1



COMPLETE REVISION

19 FEB 2025

12 PM TO 04 PM



LIVE CLASS



AFCAT 1 2025

MAHA MARATHON

19 TO 21 FEB 2025

12 PM TO 01 PM

MATHS - NAVJYOTI SIR

01 PM TO 02 PM

ENGLISH - ANURADHA MA'AM

02 PM TO 03 PM

REASONING - RUBY MA'AM

03 PM TO 04 PM

STATIC GK - DIVYANSHU SIR

 CALL US: 080-69185400

GET IT ON
Google Play

DOWNLOAD
THE APP NOW





AFCAT Exam Online Coaching 2025

AFCAT 2025: Live Classes In-Depth Lectures Study Notes Mock Tests Current Affairs Defence Current Affairs.

★★★★★ 5.0 (147)

Content 22

- Search in bundle FILTER BY TYPE
- 

AFCAT 1 2025 Live Batch - 2
Course • 331 Lessons
 - 

AFCAT 2 2024 Exam Answerkey | 09 - 11 Aug 2024 | Shift 1 & 2
Course • 228 Lessons 1 Trial
 - 

AFCAT 1 2024 Live Batch - 2
Course • 148 Lessons 2 Trials
 - 

AFCAT 1 2024 Live Batch - 1
Course • 315 Lessons 1 Trial
 - 

AFCAT Exam Overview
Course • 26 Lessons



180 Days validity

₹ 4,999 ~~₹ 5,999~~ 17% OFF

BUY BUNDLE

START A FREE TRIAL

What's included

22 Courses

Other Pricing Plans

Validity 12 Months

365 Days Validity

[Details](#)

₹5,999 ~~₹7,999~~ 25% off

BUY NOW

Bundles 13

[View All](#)



Sainik School Exam Course for Class 6

5 Courses

₹ 2,999 ~~₹ 5,999~~ 50% OFF



SSB Interview Online Coaching 2025

18 Courses

₹ 6,999 ~~₹ 9,999~~ 30% OFF

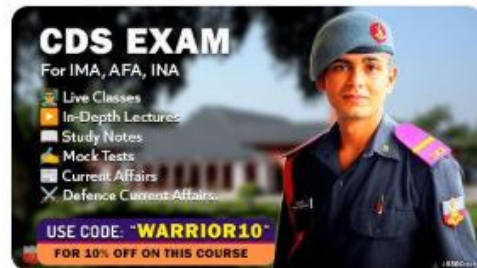

CDS Exam Online Coaching 2025

23 Courses

₹ 4,999 ~~₹ 5,999~~ 17% OFF

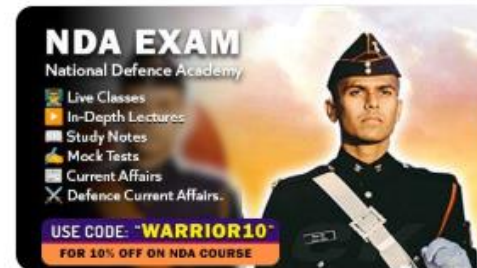

NDA Exam Online Coaching 2025

23 Courses

₹ 4,999 ~~₹ 5,999~~ 17% OFF

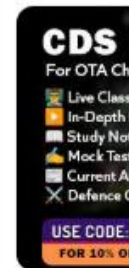

CDS Exam Online Coaching 2025

22 Courses

₹ 4,499

Test series 07

[View All](#)

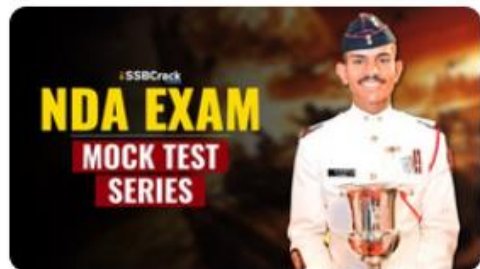

NDA Mock Test Series 2025

40 Tests

₹ 499 ~~₹ 999~~ 50% OFF



AFCAT Mock Test Series 2025

20 Tests

₹ 499 ~~₹ 999~~ 50% OFF



CDS Exam Mock Test Series 2025

30 Tests

₹ 499 ~~₹ 999~~ 50% OFF



CDS OTA Exam Mock Test Series 2025

20 Tests

₹ 499 ~~₹ 999~~ 50% OFF



MNS Mock Test Series 2025

20 Tests

₹ 499

India's Most Popular Portal for Defence Exam Preparation

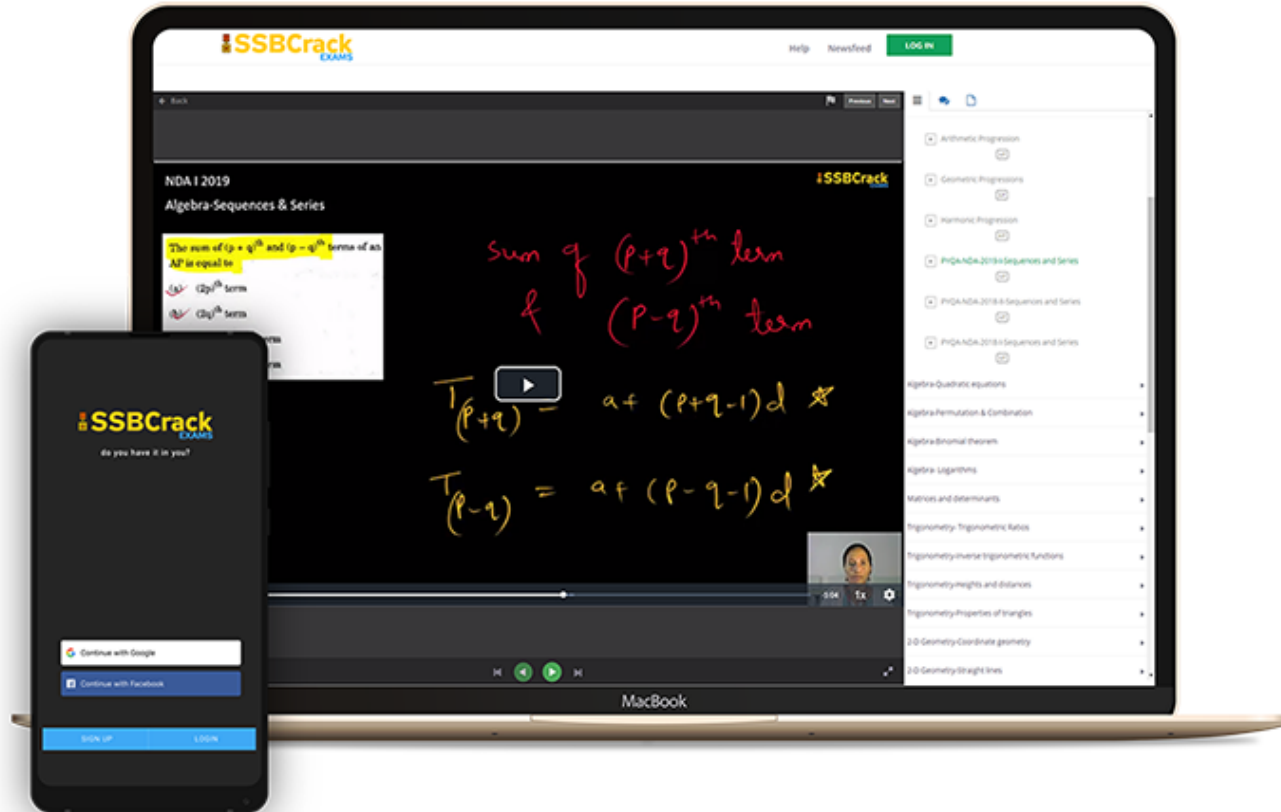
www.ssbcrackexams.com**CODE: WARRIOR10**

get an extra 10% off on all courses



Q. Who is the recipient of the 16th Timepass Booker Puraskar for their manuscript "Octopusra Atma"?

- A. Mahasweta Sahu
- B. Saral Das
- C. Dipa Karmakar
- D. Naveen Patnaik

Q. Who is the recipient of the 16th Timepass Booker Puraskar for their manuscript "Octopusra Atma"?

A. Mahasweta Sahu

B. Saral Das

C. Dipa Karmakar

D. Naveen Patnaik

Odisha: Mahashweta Sahu To Get 16th Timepass Booker Puraskar.

- **Mahasweta Sahu is awarded** the Timepass Booker Puraskar for her short story "Octopusra Atma".

- This recognition is specifically aimed at writers below the age of 45, highlighting the importance of fresh voices and innovative storytelling in Odia literature.

Q. The National Film Awards in India are presented by which organization?

- A. Ministry of Culture
- B. Ministry of Information and Broadcasting
- C. Ministry of Home Affairs
- D. Ministry of Tourism

Q. The National Film Awards in India are presented by which organization?

- A. Ministry of Culture
- B. Ministry of Information and Broadcasting**
- C. Ministry of Home Affairs
- D. Ministry of Tourism

The Directorate of Film Festivals under the Ministry of Information and Broadcasting was an organisation that initiated and presented the International Film Festival of India, the National Film Awards and the Indian Panorama.

Q. Which film won the award for Best Feature Film?

- A. Rocketry
- B. Sardar Udham
- C. RRR
- D. The Kashmir Files

Q. Which film won the award for Best Feature Film?

A. Rocketry

B. Sardar Udham

C. RRR

D. The Kashmir Files

Q. Which film won the award for Best Hindi Film?

- A. Sardar Udham
- B. Rocketry
- C. RRR
- D. The Kashmir Files

Q. Which film won the award for Best Hindi Film?

A. Sardar Udham

B. Rocketry

C. RRR

D. The Kashmir Files

Q. Which film won the award for Best Kannada Film?

- A. 777 Charlie
- B. Godavari
- C. Home
- D. Chhello Show

Q. Which film won the award for Best Kannada Film?

A. 777 Charlie

B. Godavari

C. Home

D. Chhello Show



Q. Who was the first woman to win the Jnanpith Award?

- A. Prathibha Ray
- B. Ashapoorna Devi
- C. Mahasweta Devi
- D. Indira Goswami

Q. Who was the first woman to win the Jnanpith Award?

- A. Prathibha Ray
- B. Ashapoorna Devi**
- C. Mahasweta Devi
- D. Indira Goswami



Q. The Shanti Swaroop Bhatnagar Award is given in India for contribution to the field of:

- A. sports
- B. social work
- C. science and technology
- D. literature

Q. The Shanti Swaroop Bhatnagar Award is given in India for contribution to the field of:

- A. sports
- B. social work
- C. science and technology**
- D. literature



शांतिस्वरूप भटनागर पुरस्कार



Q. The Jnanpith Award is given for excellence in which of the following fields?

- A. Medicine
- B. Social work
- C. Literature
- D. Cinema

Q. The Jnanpith Award is given for excellence in which of the following fields?

- A. Medicine
- B. Social work
- C. Literature**
- D. Cinema



Q. Who won the 2024 Pulitzer Prize for Fiction?

- A. Samantha Harvey
- B. Jayne Anne Phillips
- C. Han King
- D. Jenny Erpenbeck

Q. Who won the 2024 Pulitzer Prize for Fiction?

- A. Samantha Harvey
- B. Jayne Anne Phillips**
- C. Han King
- D. Jenny Erpenbeck

Q. Which book won the 2024 Booker Prize?

- A. Night Watch
- B. Kairos
- C. Orbital
- D. The Fragile Thread

Q. Which book won the 2024 Booker Prize?

- A. Night Watch
- B. Kairos
- C. Orbital**
- D. The Fragile Thread

Q. Who won the 2024 Booker International Prize?

- A. Han King
- B. Michael Hofmann
- C. Jayne Anne Phillips
- D. Jenny Erpenbeck

Q. Who won the 2024 Booker International Prize?

- A. Han King
- B. Michael Hofmann
- C. Jayne Anne Phillips
- D. Jenny Erpenbeck**

Q. Why was Han King awarded the 2024 Nobel Prize in Literature?

- A. For her science fiction narratives on human advancement
- B. For her intense poetic prose confronting historical traumas
- C. For her contributions to modern theater
- D. For her groundbreaking work in translation

Q. Why was Han King awarded the 2024 Nobel Prize in Literature?

- A. For her science fiction narratives on human advancement
- B. For her intense poetic prose confronting historical traumas**
- C. For her contributions to modern theater
- D. For her groundbreaking work in translation

Q. What is the title of the work for which Prabha Varma won the Saraswati Samman 2024?

- A. Roudra Sathwikam
- B. Jnanpith Kavita
- C. Saraswati Geet
- D. Poetic Symphony

Q. What is the title of the work for which Prabha Varma won the Saraswati Samman 2024?

A. Roudra Sathwikam

B. Jnanpith Kavita

C. Saraswati Geet

D. Poetic Symphony

Q. Who were the recipients of the 58th Jnanpith Award 2024?

- A. KK Birla and Gulzar
- B. Gulzar and Jagadguru Rambhadracharya
- C. Prabha Varma and Gulzar
- D. Jagadguru Rambhadracharya and KK Birla

Q. Who were the recipients of the 58th Jnanpith Award 2024?

- A. KK Birla and Gulzar
- B. Gulzar and Jagadguru Rambhadracharya**
- C. Prabha Varma and Gulzar
- D. Jagadguru Rambhadracharya and KK Birla

Q. Which of the following is the capital of Belarus?

- A. Baku
- B. Minsk
- C. Moroni
- D. Brussels

Q. Which of the following is the capital of Belarus?

- A. Baku
- B. Minsk**
- C. Moroni
- D. Brussels



- Minsk is the capital of Belarus.
- Belarus Currency- **Belarusian ruble.**

Q. Which among the following is the capital of Latvia?

- A. Tripoli
- B. Riga
- C. Kabul
- D. Castries

Q. Which among the following is the capital of Latvia?

- A. Tripoli
- B. Riga**
- C. Kabul
- D. Castries



Q. Which of the following is the capital of Cambodia?

- A. Nicosia
- B. Hanoi
- C. Phnom Penh
- D. Dili

Q. Which of the following is the capital of Cambodia?

- A. Nicosia
- B. Hanoi
- C. Phnom Penh
- D. Dili



- **Phnom Penh** is the capital of Cambodia.
- **Nicosia** is the capital of Cyprus.
- **Hanoi** is the capital of Vietnam.
- **Dili** is the capital of Timor-Leste.

Q. Manat is the currency of which country?

- A. Azerbaijan
- B. Armenia
- C. Albania
- D. Andorra

Q. Manat is the currency of which country?

A. Azerbaijan

B. Armenia

C. Albania

D. Andorra



Q. Which among the following is the capital of Cyprus?

- A. Tripoli
- B. Lefkosia
- C. Kabul
- D. Castries

Q. Which among the following is the capital of Cyprus?

- A. Tripoli
- B. Lefkosia**
- C. Kabul
- D. Castries



Q. Which of the following is the capital of Iraq?

- A. Nicosia
- B. Tehran
- C. Baghdad
- D. Dili

Q. Which of the following is the capital of Iraq?

- A. Nicosia
- B. Tehran
- C. Baghdad
- D. Dili



Q. Jordanian dinar is the currency of which country?

- A. Azerbaijan
- B. Armenia
- C. Albania
- D. Jordan

Q. Jordanian dinar is the currency of which country?

- A. Azerbaijan
- B. Armenia
- C. Albania
- D. Jordan**



Q. What is the currency of the Philippines?

- A. Renminbi
- B. Rial
- C. Rouble
- D. Philippine peso

Q. What is the currency of the Philippines?

- A. Renminbi
- B. Rial
- C. Rouble
- D. Philippine peso**



Q. What is the currency of Peru called?

A. Rupee

B. Real

C. Sol

D. Peso

Q. What is the currency of Peru called?

- A. Rupee
- B. Real
- C. Sol**
- D. Peso



Q. Thimphu is the capital of which Border Nation of India?

- A. Bhutan
- B. Nepal
- C. Afghanistan
- D. Myanmar

Q. Thimphu is the capital of which Border Nation of India?

A. Bhutan

B. Nepal

C. Afghanistan

D. Myanmar



Q. Bhagoria festival is a popular festival in the state of _.

- A. Assam
- B. Maharashtra
- C. Nagaland
- D. Madhya Pradesh

Q. Bhagoria festival is a popular festival in the state of _.

- A. Assam
- B. Maharashtra
- C. Nagaland
- D. Madhya Pradesh**



Q. Tejaji Pashu Mela Rajasthan is famous for which one of the following?

- A. Nachna Camel
- B. Murrah Buffalo
- C. Nagauri Cow
- D. Chokhla Sheep

Q. Tejaji Pashu Mela Rajasthan is famous for which one of the following?

- A. Nachna Camel
- B. Murrah Buffalo
- C. Nagauri Cow**
- D. Chokhla Sheep



Q. Onam is a festival celebrated in which Indian state?

- A. Karnataka
- B. Kerala
- C. Goa
- D. Tamil Nadu

Q. Onam is a festival celebrated in which Indian state?

- A. Karnataka
- B. Kerala**
- C. Goa
- D. Tamil Nadu



Q. Wangala festival is celebrated in which state of India?

- A. Manipur
- B. Mizoram
- C. Sikkim
- D. Meghalaya

Q. Wangala festival is celebrated in which state of India?

- A. Manipur
- B. Mizoram
- C. Sikkim
- D. Meghalaya**



Q. Which of the following dance forms is performed in the form of Question and Answers ?

- A. Phag
- B. Dhamal
- C. Loor
- D. Jhumar

Q. Which of the following dance forms is performed in the form of Question and Answers ?

A. Phag

- **Loor dance** is a popular traditional folk dance from **Haryana**, a state in northern India.

B. Dhamal

- It's a way for the locals to express **joy and sadness**, just like any other folk dance.
- It is highly famous in **Haryana's Bangar and Bagar regions**.

C. Loor

- It is held in the month of '**Phalguna**,' which corresponds to the **months of February and March** in the Gregorian calendar.

D. Jhumar

Q. Which state of India organizes 'Rann Utsav' every year?

- A. Maharashtra
- B. Gujarat
- C. Madhya Pradesh
- D. Rajasthan

Q. Which state of India organizes 'Rann Utsav' every year?

- A. Maharashtra
- B. Gujarat**
- C. Madhya Pradesh
- D. Rajasthan



Q. 'Uruka' is a traditional festival of the state of _____.

- A. Tamil Nadu
- B. Sikkim
- C. Kerala
- D. Assam

Q. 'Uruka' is a traditional festival of the state of _____.

- A. Tamil Nadu
- B. Sikkim
- C. Kerala
- D. Assam**



Q. Igas festival is related to which state?

A. Manipur

B. Uttarakhand

C. Karnataka

D. Kerala

• Igas Festival:

- Igas festival is also known as Budhi Diwali.
- This is the 5-day long festival, start on the first 'Amavasya after the regular Diwali.
- It is celebrated by the people of the Jaunsar Bawar region in Uttarakhand.
- one month after Diwali as it is believed that the news of Lord Ram's homecoming to Ayodhya reached the hills late.
- People celebrate it by dancing with Virah songs.
- The Rasa Dance is one of the major attractions during the celebration.

Q. The Rath Yatra at Puri is celebrated in Honour of which Hindu deity?

- A. Ram
- B. Kartikeya
- C. Shiva
- D. Jagannath

Q. The Rath Yatra at Puri is celebrated in Honour of which Hindu deity?

- A. Ram
- B. Kartikeya
- C. Shiva
- D. Jagannath**



Q. Hornbill Festival is celebrated in which the state of India?

- A. Manipur
- B. Nagaland
- C. Meghalaya
- D. Mizoram

Q. Hornbill Festival is celebrated in which the state of India?

- A. Manipur
- B. Nagaland**
- C. Meghalaya
- D. Mizoram



Q. Karakoram mountain range is located in which of the following states/UT?

- A. Jammu and Kashmir
- B. Manipur
- C. Assam
- D. Meghalaya

Q. Karakoram mountain range is located in which of the following states?

A. Jammu and Kashmir

B. Manipur

C. Assam

D. Meghalaya



Q. Which is the Largest Ocean in the world?

- A. Atlantic Ocean
- B. Pacific Ocean
- C. Indian Ocean
- D. Arctic Ocean

Q. Which is the Largest Ocean in the world?

- A. Atlantic Ocean
- B. Pacific Ocean**
- C. Indian Ocean
- D. Arctic Ocean

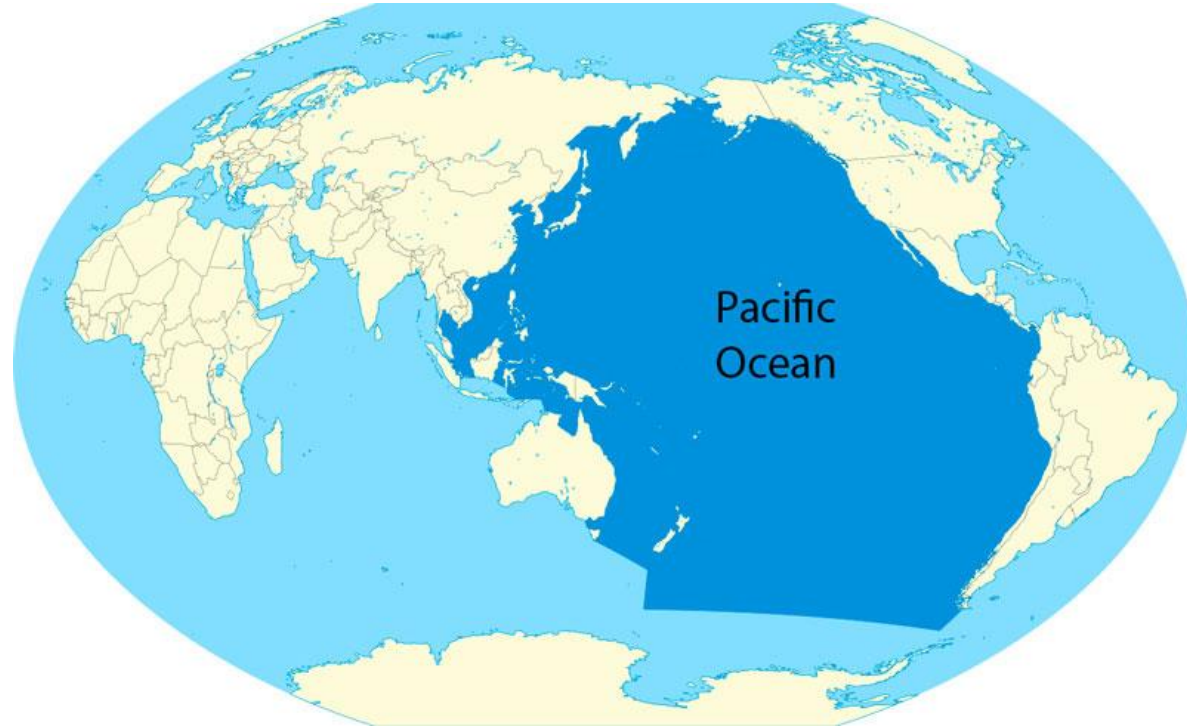

Q. Which is the Largest airport in the world?

- A. London Heathrow Airport
- B. King Fahd Airport
- C. Beijing Capital International Airport
- D. Tokyo International Airport

Q. Which is the Largest airport in the world?

- A. London Heathrow Airport
- B. King Fahd Airport**
- C. Beijing Capital International Airport
- D. Tokyo International Airport

Q. Which one is the smallest planet in Solar System?

- A. Mercury
- B. Earth
- C. Mars
- D. Neptune

Q. Which one is the smallest planet in Solar System?

A. Mercury

B. Earth

C. Mars

D. Neptune

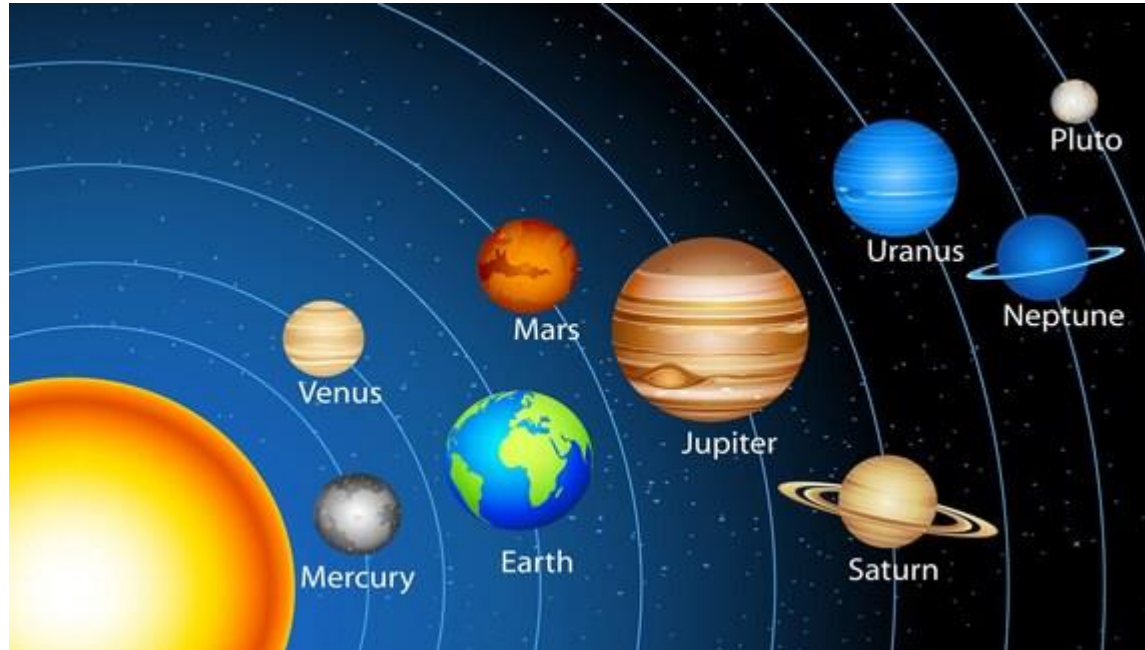

Q. Which is the longest River in the World?

- A. Nile
- B. Ganga
- C. Yamuna
- D. Kaveri

Q. Which is the longest River in the World?

A. Nile

B. Ganga

C. Yamuna

D. Kaveri

Q. Which of the following rivers is also known as Yarlung Tsangpo in the Tibet region of China?

- A. Indus
- B. Sutlej
- C. Brahmaputra
- D. Teesta

Q. Which of the following rivers is also known as Yarlung Tsangpo in the Tibet region of China?

- A. Indus
 - B. Sutlej
 - C. Brahmaputra**
 - D. Teesta
- The Yarlung Tsangpo River is the longest river in the Tibet Region, China.
 - Downstream from Arunachal Pradesh, the river becomes wider and after reaching Assam, the river is known as the Brahmaputra.
 - The river is called the Everest of Rivers because of its extreme conditions.
 - It is also called the Dihang River in Arunachal Pradesh.
 - It originates from the Manasarovar Lake region, near Mount Kailash.
 - It flows southwest through the Assam Valley as the Brahmaputra and south through Bangladesh as the Jamuna.
 - It merges with the Ganges, popularly known as the Padma in Bangladesh, becomes the Meghna, and ultimately empties into the Bay of Bengal.

Q. Guru Shikhar is the highest peak of which of the following ranges?

A. Chotanagpur

B. Aravalli

C. Vindhya

D. Malwa

Q. Guru Shikhar is the highest peak of which of the following ranges?

A. Chotanagpur

B. **Aravalli**

C. Vindhya

D. Malwa

Q. The tallest waterfall in India with a height of 1,493 ft is _____.

- A. Meenmutty Falls, Kerala
- B. Kunchikal Falls, Karnataka
- C. Barkana Falls, Karnataka
- D. Thalaiyar Falls, Tamil Nadu

Q. The tallest waterfall in India with a height of 1,493 ft is _____.

A. Meenmutty Falls, Kerala

B. Kunchikal Falls, Karnataka

C. Barkana Falls, Karnataka

D. Thalaiyar Falls, Tamil Nadu

- Kunchikal Falls, also called Kunchikal Abbe, is located near Masthikatte-Hulikal bordering the Udupi-Shimoga districts of the state of Karnataka.
- Kunchikal falls is formed by the Varahi River.
- Kunchikal falls cascade down rocky boulders and the total height of the fall is 455 meters.

Q. The highest waterfall in the world is:

- A. Tugela
- B. Angel
- C. Cuquenán
- D. Takkawa

Q. The highest waterfall in the world is:

- A. Tugela
- B. Angel**
- C. Cuquenán
- D. Takkawa



Angel Falls is a waterfall in Venezuela. It is the world's tallest uninterrupted waterfall, with a height of 979 meters and a plunge of 807 m. The waterfall drops over the edge of the Auyán-tepui mountain in the Canaima National Park, a UNESCO World Heritage site in the Gran Sabana region of Bolívar State.

Q. The second-highest waterfall in the world:

- A. Aniene
- B. Skykje
- C. Tugela
- D. Kibbon

Q. The second-highest waterfall in the world:

A. Aniene

B. Skykje

C. Tugela

D. Kibbon

Tugela Falls is a complex of seasonal waterfalls located in the Drakensberg of Royal Natal National Park in KwaZulu-Natal Province, Republic of South Africa. According to some measurements, it is the world's tallest waterfall.



Q. Which is the smallest mammal in the world?

- A. Bumblebee Bat
- B. Etruscan Shrew
- C. Pygmy Jerboa
- D. Pygmy Marmoset

Q. Which is the smallest mammal in the world?

A. Bumblebee Bat

B. Etruscan Shrew

C. Pygmy Jerboa

D. Pygmy Marmoset



Kitti's hog-nosed bat, also known as the bumblebee bat, is a near-threatened species of bat and the only extant member of the family Craseonycteridae. It occurs in western Thailand and southeast Myanmar, where it occupies limestone caves along rivers.

Q. The roots of the 1857 revolt lay in

- A. Blatantly discriminatory policies
- B. Exploitative land revenue policy
- C. The policy of greased cartridges
- D. All of the above

Q. The roots of the 1857 revolt lay in

- A. Blatantly discriminatory policies
- B. Exploitative land revenue policy
- C. The policy of greased cartridges
- D. All of the above**

The British ruled over India for about two centuries. They started interference in the religious matters and other social practices of Hindus and Muslims, and it infuriated the Indians and their anger resulted in the armed revolt of 1857. The roots of the 1857 revolt lay in Blatantly discriminatory policies, exploitative land revenue policy and the policy of greased cartridges.

Q. Which of the following event was the reason for the withdrawn of non cooperation movement?

- A. Chauri Chaura incident
- B. Jallianwala massacre
- C. Gandhi Imprisonment
- D. None

Q. Which of the following event was the reason for the withdrawn of non cooperation movement?

- A. Chauri Chaura incident
- B. Jallianwala massacre
- C. Gandhi Imprisonment**
- D. None

The Non-cooperation movement was withdrawn because of the Chauri Chaura incident. Although he had stopped the national revolt single-handedly, on 10 March 1922, Gandhi was arrested. This led to suppression of the movement and was followed by the arrest of other leaders.

Q. Which of the following leader was not moderate?

- A. Dada Bhai Naoroji
- B. Anand Charlu
- C. Bipin Chandra Pal
- D. Madan Mohan Malviya

Q. Which of the following leader was not moderate?

- A. Dada Bhai Naoroji
- B. Anand Charlu
- C. Bipin Chandra Pal**
- D. Madan Mohan Malviya

Bipin Chandra Pal (7 November 1858 – 20 May 1932) was an Indian nationalist, a freedom fighter, writer, orator and social reformer of Sylheti origin. He was one of the main architects of the Swadeshi movement. He stood against the partition of West Bengal. He was not moderate.

Q. The Indian National Association was established in 1876 by _____ in Calcutta.

- A. Badruddin Tyabji
- B. Anand Mohan Bose
- C. V. K. Chiplunkar
- D. More than one of the above

Q. The Indian National Association was established in 1876 by _____ in Calcutta.

- A. Badruddin Tyabji
- B. Anand Mohan Bose**
- C. V. K. Chiplunkar
- D. More than one of the above

- The **Indian National Association** was established in 1876 by **Surendranath Banerjee** and **Anand Mohan Bose** in Calcutta now Kolkata.
- The **Indian National Association** was initially established as **Bharat Sabha** and in 1885, it merged with **Indian National Congress (INC)**.
- Surendranath Banerjee**, an eminent leader of INC, is also known as **Rashtra Guru**.

Q. After the failure of the Civil Disobedience Movement, Gandhiji laid emphasis on

- A. compromise with the British
- B. limited use of Violence
- C. constructive programme
- D. More than one of the above

Q. After the failure of the Civil Disobedience Movement, Gandhiji laid emphasis on

- A. compromise with the British
- B. limited use of Violence
- C. constructive programme**
- D. More than one of the above

- After the failure of the Civil Disobedience Movement in 1934, Mahatma Gandhi laid emphasis on constructive programmes.
- He believed that the constructive programme was essential for the all-round development of India, and that it would provide a strong foundation for the country's independence.

Q. The famous Lucknow pact of 1916 was signed between _____.

- A. Mahatma Gandhi and Aga Khan
- B. Bal Gangadhar Tilak and Muhammad Ali Jinnah
- C. Mahatma Gandhi and Muhammad Ali Jinnah
- D. Bal Gangadhar Tilak and Aga Khan

Q. The famous Lucknow pact of 1916 was signed between _____.

- A. Mahatma Gandhi and Aga Khan
- B. Bal Gangadhar Tilak and Muhammad Ali Jinnah**
- C. Mahatma Gandhi and Muhammad Ali Jinnah
- D. Bal Gangadhar Tilak and Aga Khan

- The Lucknow Pact was an agreement between the Indian National Congress and the Muslim League at a joint session of both the parties held in Lucknow in December 1916.
- The Lucknow Pact of 1916 is signed between Bal Gangadhar Tilak and Muhammad Ali Jinnah.
- As a result of this agreement, The Muslim League leaders agreed to join the Congress movement demanding Indian independence.
- The Lucknow Pact was seen as a **beacon of hope to Hindu–Muslim unity**.

Q. Who was credited with the establishment of Servants of India Society?

- A. Gopal Krishna Gokhale
- B. Lala Lajpat Rai
- C. C R Das
- D. Raja Rammohan RoyKhan

Q. Who was credited with the establishment of Servants of India Society?

A. Gopal Krishna Gokhale

B. Lala Lajpat Rai

C. C R Das

D. Raja Rammohan RoyKhan

Name of the organization	Place	Founder	Year
Servants of India Society	Pune	Gopal Krishna Gokhale	1905
Brahmo Samaj	Kolkata	Raja Rammohan Roy	1828
Servants of the People Society	Lahore	Lala Lajpat Rai	1921
Swaraj party	-	Motilal Nehru CR Das	1923
Deccan Education Society	Pune	Bal Gangadhar Tilak	1884

Q. The word Swaraj was first used by Dadabhai Naoroji in the congress session held in _____ at _____.

- A. 1904, Bombay
- B. 1906, Calcutta
- C. 1907, Surat
- D. 1916, Lucknow

Q. The word Swaraj was first used by Dadabhai Naoroji in the congress session held in _____ at _____.

- A. 1904, Bombay
- B. 1906, Calcutta**
- C. 1907, Surat
- D. 1916, Lucknow

Q. All India Congress Committee (AICC) meeting to ratify the Quit India resolution was held at _____ session.

- A. Faizpuri
- B. Calcutta
- C. Bombay
- D. Tripuri

Q. All India Congress Committee (AICC) meeting to ratify the Quit India resolution was held at _____ session.

A. Faizpuri

B. Calcutta

C. Bombay

D. Tripuri

- It was passed by Mahatma Gandhi on **8th August 1942**.
- Mahatma Gandhi issued the Quit India speech at the **Gowalia tank maidan in Mumbai**.
- The All-India congress committee is the central decision-making assembly of the Indian National Congress.
- The All-India congress committee launched a mass protest demanding the withdrawal of British rule from India in 1942.

Q. Freedom Fighter Shaheed Bhagat Singh was associated with which of the following Organisation?

- A. The Swaraj Party
- B. Indian National Congress
- C. Hindustan Socialist Republican Association
- D. Both Indian National Congress and Hindustan Socialist Republican Association (HSRA)

Q. Freedom Fighter Shaheed Bhagat Singh was associated with which of the following Organisation?

- A. The Swaraj Party
- B. Indian National Congress
- C. Hindustan Socialist Republican Association**
- D. Both Indian National Congress and Hindustan Socialist Republican Association (HSRA)

Q. Whose death coincided with the launch of the non-cooperation movement in 1920?

- A. GK Gokhale
- B. Motilal Nehru
- C. Dadabhai Naoroji
- D. Lokmanya Tilak

Q. Whose death coincided with the launch of the non-cooperation movement in 1920?

- A. GK Gokhale
- B. Motilal Nehru
- C. Dadabhai Naoroji
- D. Lokmanya Tilak**

Q. Which of the three freedom fighters of India were hanged to death in the Kakori Train Conspiracy in 1925?

- A. Roshan Singh, Ram Prasad Bismil and Ashfaqulla Khan
- B. Bhagat Singh, Sukhdev, Rajguru
- C. Sardar Udham Singh, Ram Prasad Bismil, Ashfaqulla Khan
- D. Ram Prasad Bismil, Bhagat Singh, Ashfaqulla Khan

Q. Which of the three freedom fighters of India were hanged to death in the Kakori Train Conspiracy in 1925?

- A. Roshan Singh, Ram Prasad Bismil and Ashfaqulla Khan**
- B. Bhagat Singh, Sukhdev, Rajguru
- C. Sardar Udham Singh, Ram Prasad Bismil, Ashfaqulla Khan
- D. Ram Prasad Bismil, Bhagat Singh, Ashfaqulla Khan

Q. Which of the following statement is not correct in reference to Swadeshi movement during Indian freedom struggle?

- A. The Surat split in 1907 weakened the Swadeshi movement.
- B. The Ganapati and Shivaji festival became a medium of the movement.
- C. Syed Haider Raza led the Swadeshi movement in India.
- D. More than one of the above

Q. Which of the following statement is not correct in reference to Swadeshi movement during Indian freedom struggle?

- A. The Surat split in 1907 weakened the Swadeshi movement.
- B. The Ganapati and Shivaji festival became a medium of the movement.
- C. Syed Haider Raza led the Swadeshi movement in India.**
- D. More than one of the above

•October 16, 1905, the day the partition formally came into force, was observed as a day of mourning throughout Bengal. 'Amar Sonar Bangla', the national anthem of present-day Bangladesh, was composed by Rabindranath Tagore.

Q. Who was the political guru of Subhash Chandra Bose?

- A. M. G. Ranade
- B. Mahatma Gandhi
- C. Gopala Krishna Gokhale
- D. Chittaranjan Das

Q. Who was the political guru of Subhash Chandra Bose?

- A. M. G. Ranade
- B. Mahatma Gandhi
- C. Gopala Krishna Gokhale
- D. Chittaranjan Das**

- Subhash Chandra Bose was born on **23rd January 1897**, in Cuttack, Orissa Division, Bengal Province.
- The birth anniversary of Netaji on 23rd January is celebrated as '**Parakram Diwas**'.
- Subhash Chandra Bose is popularly known as '**Netaji**'.
- He passed the **Indian Civil Services Examination in 1920** in England but left it on Gandhiji's call of the Non-cooperation Movement.

Q. Tribal Research and Development Institute is situated at which of the following place?

- A. Indore
- B. Bhopal
- C. Jhabua
- D. Datia

Q. Tribal Research and Development Institute is situated at which of the following place?

A. Indore

B. Bhopal

C. Jhabua

D. Datia

- Tribal Research and Development Institute is situated in Bhopal.
- Tribal Research and Development Institute is an organization of the Government of Madhya Pradesh.
- It is under the administrative control of the Tribal Welfare Department of the State Government.
- It receives financial assistance from the Government of India, Ministry of Tribal Affairs, and is engaged in tribal research.

Q. Where is the National Institute Agricultural Marketing (NIAM) located?

- A. New Delhi
- B. Jaipur
- C. Hisar
- D. Bhopal

Q. Where is the National Institute Agricultural Marketing (NIAM) located?

A. New Delhi

B. Jaipur

C. Hisar

D. Bhopal

- National Institute of Agricultural Marketing (NIAM) is a national level institute set up by the Ministry of Agriculture, on 8 August 1988 at Jaipur, Rajasthan, to cater to the needs of agricultural marketing personnel and to offer specialized Training, Research, Consultancy, and Education in Agricultural Marketing in India and Southeast Asian countries.
- The institute is dedicated to Chaudhary Charan Singh, the fifth prime minister of India from where it derives its full name, "Chaudhary Charan Singh National Institute of Agricultural Marketing".

Q. In which city is Indian Railway-Rail Coach Factory located?

- A. Bengaluru
- B. Kapurthala
- C. Chennai
- D. Chittaranjan

Q. In which city is Indian Railway-Rail Coach Factory located?

A. Bengaluru

B. Kapurthala

C. Chennai

D. Chittaranjan

- Kapurthala Rail Coach Factory is a coach manufacturing unit for the Indian Railways, located in the state of Punjab.
- It is located on the Jalandhar-Firozpur railway line.
- Established in 1986, RCF has manufactured more than 30,000 passenger coaches of various types, including self-propelled passenger vehicles, making up more than 50% of the total Indian Railway coach population.
- It is a production unit with a per-year target of 1025 coaches.
- This production accounts for over 35 percent of the total Indian Railway coach population.

Q. Who established the Atomic Energy Commission (AEC) of India in 1948?

- A. P.K. Iyengar
- B. M.R. Srinivasan
- C. Vikram Sarabhai
- D. Homi Bhabha

Q. Who established the Atomic Energy Commission (AEC) of India in 1948?

A. P.K. Iyengar

B. M.R. Srinivasan

C. Vikram Sarabhai

D. Homi Bhabha

- The Indian Atomic Energy Commission was formed on 1st March 1948.
- The commission was created on 10th August 1948 by the Department of Scientific Research.
- The first Prime Minister of India late Pandit Jawaharlal Nehru was the main protagonist behind this commission. He also presented a copy of this Resolution during the Lok Sabha held on 24th March 1958.
- The Department of Atomic Energy (DAE) was set up on 3rd August 1954. It is under the direct charge of the Prime Minister of India, through a Presidential Order.

Q. Netaji Subhas National Institute of Sports is located at _____.

- A. Ranchi
- B. Bangalore
- C. Patiala
- D. Mohali

Q. Netaji Subhas National Institute of Sports is located at _____.

A. Ranchi

- Netaji Subhas National Institute of Sports is located at Patiala.

B. Bangalore

- Netaji Subhas National Institute of Sports commonly known as the National Institute of Sports (NIS).

C. Patiala

- It is the Academic Wing of the Sports Authority of India (SAI)

- It is Asia's largest Sports Institute.

D. Mohali

- This Institute is popularly known as the “Mecca” of Indian Sports.

- It was established by the Government of India on 7th May 1961.

Q. The headquarters of UNHCR is located at

- A. New York
- B. Rome
- C. Geneva
- D. London

Q. The headquarters of UNHCR is located at

- A. New York
- B. Rome
- C. Geneva**
- D. London

Name: United Nations High
Commissioner for Refugees
(UNHCR)

Year of formation: 1950

HQ: Geneva, Switzerland

Sector: Refugee &
displaced persons relief



Q. Besides UK, USA, Germany and Japan the G-7 countries includes

- A. Canada, France and Russia
- B. Canada, Italy and Netherlands
- C. France, Netherlands and Russia
- D. Canada, France and Italy

Q. Besides UK, USA, Germany and Japan the G-7 countries includes

- A. Canada, France and Russia
- B. Canada, Italy and Netherlands
- C. France, Netherlands and Russia
- D. Canada, France and Italy**

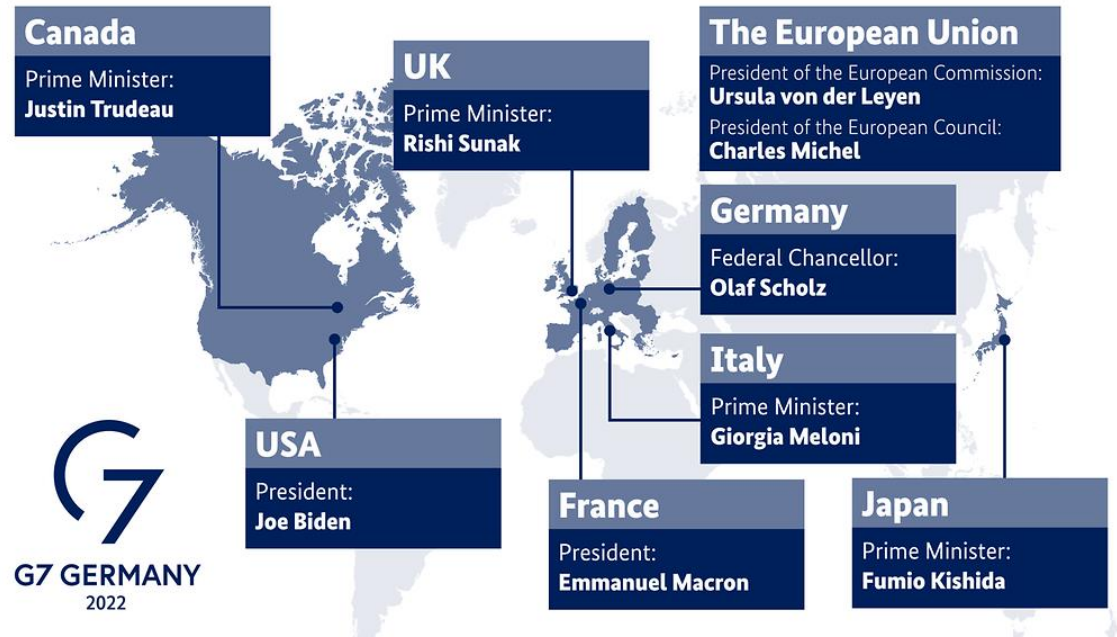

Q. Amnesty International has its headquarters at

- A. Berlin
- B. New York
- C. Washington
- D. London

Q. Amnesty International has its headquarters at

- A. Berlin
- B. New York
- C. Washington
- D. London**

**AMNESTY
INTERNATIONAL**



Q. The headquarters of the International Labour Organization is at

- A. Paris
- B. New York
- C. Hague
- D. Geneva

Q. The headquarters of the International Labour Organization is at

- A. Paris
- B. New York
- C. Hague
- D. Geneva**

NAME: INTERNATIONAL LABOUR ORGANISATION
(ILO)
A SPECIALIZED AGENCY OF THE UN

YEAR OF FORMATION: 1946

HQ: GENEVA, SWITZERLAND

SECTOR: LABOUR ISSUES

IS INDIA A MEMBER: YES



**International
Labour
Organization**

Q. The headquarters of World Intellectual Property Organization (WIPO) is located in

- A. Paris
- B. Madrid
- C. New York
- D. Geneva

Q. The headquarters of the World Intellectual Property Organization (WIPO) is located in

- A. Paris
- B. Madrid
- C. New York
- D. Geneva**



WIPO
WORLD
INTELLECTUAL PROPERTY
ORGANIZATION

Formation: 14th July 1967.

HQ: Geneva, Switzerland

193 member states

One of the 15 specialized agencies of the United Nations (UN).

Discuss and shape international IP rules and policies

Released the World Intellectual Property Indicators 2019

Patent filings- 5.2% growth

China	1	452804
U.S.	2	354430
Japan	3	179910

Q. The headquarter of the International Committee of the Red Cross are at

- A. Geneva
- B. Paris
- C. Rome
- D. Stockholm

Q. The headquarter of the International Committee of the Red Cross are at

- A. Geneva**
- B. Paris
- C. Rome
- D. Stockholm

INTERNATIONAL COMMITTEE OF THE RED CROSS (ICRC)

ICRC is an independent humanitarian institution of a private character, neutral as regards to political opinions, ideology and religion. The Assembly is the supreme policy-making body of ICRC. It was formed in 1863.

ROLES

- 📌 Promoter of Geneva Convention**
- 📌 Neutral Institution**
- 📌 Right of Initiative**
- 📌 Guardian of Principles**
- 📌 Protect the Wounded, POWs and Internees**
- 📌 Feed, Clothe and House Prisoners & Internees**

Q. What is the purpose of OECD (Organization for Economic Cooperation and Development)?

- A. Sustained economic growth
- B. Employment
- C. Higher standards of living
- D. All of the above

Q. What is the purpose of OECD (Organization for Economic Cooperation and Development)?

- A. Sustained economic growth
- B. Employment
- C. Higher standards of living
- D. All of the above**

What Is the OECD? (Organization for Economic Cooperation and Development)

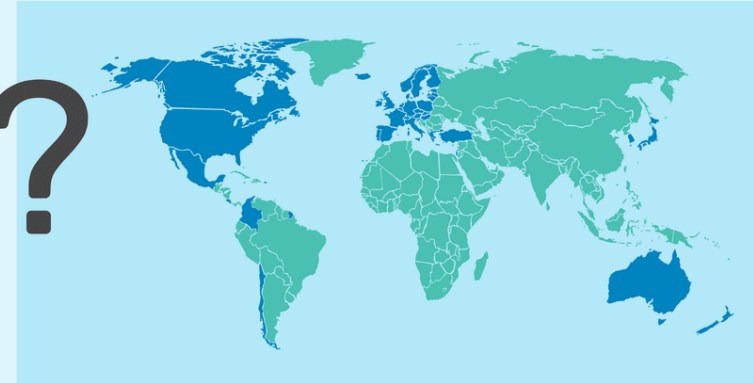

- It aids developing countries outside membership and promotes reform

- It is an association of 38 nations in Europe, the Americas, and the Pacific

- It helps member countries formulate economic and social policies

- Members and key partners represent 80% of world trade

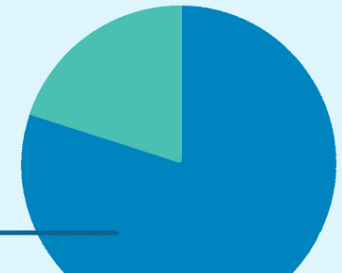

Q. What is the role of WTO (World Trade Organization)?

- A. To settle trade disputes between nations
- B. To widen the principal of free trade to sectors such as services and agriculture
- C. Both (a) and (b)
- D. None of the above

Q. What is the role of WTO (World Trade Organization)?

- A. To settle trade disputes between nations
- B. To widen the principal of free trade to sectors such as services and agriculture
- C. Both (a) and (b)**
- D. None of the above

Q. The headquarter of the International Court of Justice are at

- A. Geneva
- B. The Hague
- C. Rome
- D. Vienna

Q. The headquarter of the International Court of Justice are at

- A. Geneva
- B. The Hague**
- C. Rome
- D. Vienna



Q. The headquarters of UNESCO is at

- A. New York
- B. Paris
- C. Geneva
- D. Rome

Q. The headquarters of UNESCO is at

- A. New York
- B. Paris**
- C. Geneva
- D. Rome



Q. The headquarters of BIMSTEC is located in

- A. Paris
- B. Madrid
- C. Dhaka
- D. Bangkok

Q. The headquarters of BIMSTEC is located in

- A. Paris
- B. Madrid
- C. Dhaka
- D. Bangkok

BIMSTEC

WHAT YOU SHOULD KNOW



Stands for **The Bay of Bengal Initiative for Multi-Sectoral Technical and Economic Cooperation**

Founded in 1997 through **Bangkok Declaration**

7 MEMBER COUNTRIES

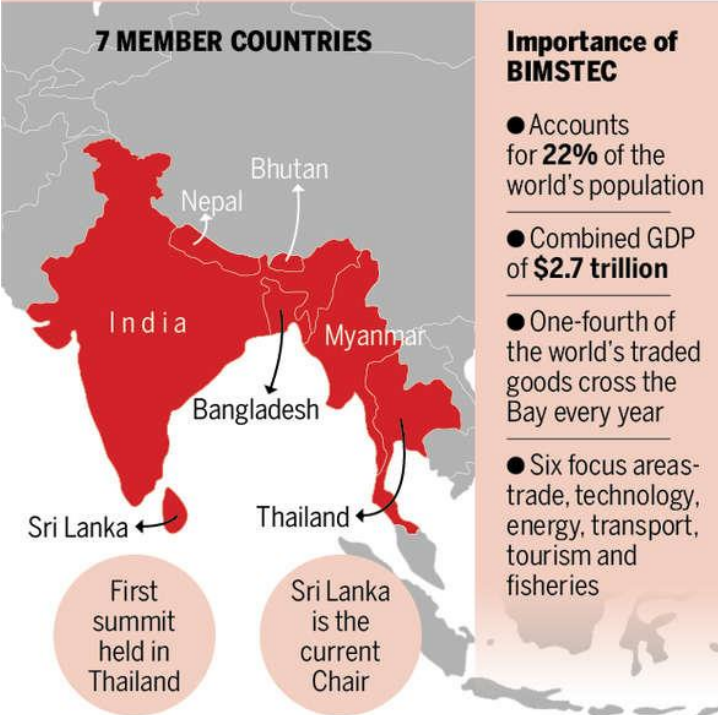

Importance of BIMSTEC

- Accounts for **22%** of the world's population
- Combined GDP of **\$2.7 trillion**
- One-fourth of the world's traded goods cross the Bay every year
- Six focus areas—trade, technology, energy, transport, tourism and fisheries

First summit held in Thailand

Sri Lanka is the current Chair

Q. Which of the following describe correctly the Group of Seven Countries (G-7)?

- A. They are developing countries
- B. They are industrialized countries
- C. They are holding Atomic Bomb technology
- D. They are the countries that can launch their own satellites

Q. Which of the following describe correctly the Group of Seven Countries (G-7)?

- A. They are developing countries
- B. They are industrialized countries**
- C. They are holding Atomic Bomb technology
- D. They are the countries that can launch their own

G7

Group of Seven



Canada



Italy



United Kingdom



France



Japan



United States



Germany



European Union

Q. Which of the following countries is not a member of SAARC?

- A. Nepal
- B. Bangladesh
- C. Afghanistan
- D. Myanmar

Q. Which of the following countries is not a member of SAARC?

A. Nepal

B. Bangladesh

C. Afghanistan

D. Myanmar



Q. Where is the permanent secretariat of the SAARC?

- A. Kathmandu
- B. New Delhi
- C. Islamabad
- D. Colombo

Q. Where is the permanent secretariat of the SAARC?

A. Kathmandu

B. New Delhi

C. Islamabad

D. Colombo

Q. Which of the following is the headquarters of World Trade Organization (WTO)?

- A. New York
- B. Geneva
- C. Madrid
- D. Paris

Q. Which of the following is the headquarters of World Trade Organization (WTO)?

- A. New York
- B. Geneva**
- C. Madrid
- D. Paris



Q. The headquarters of the International Atomic Energy Agency is located in

- A. Vienna
- B. London
- C. Geneva
- D. Washington

Q. The headquarters of the International Atomic Energy Agency is located in

- A. Vienna**
- B. London
- C. Geneva
- D. Washington

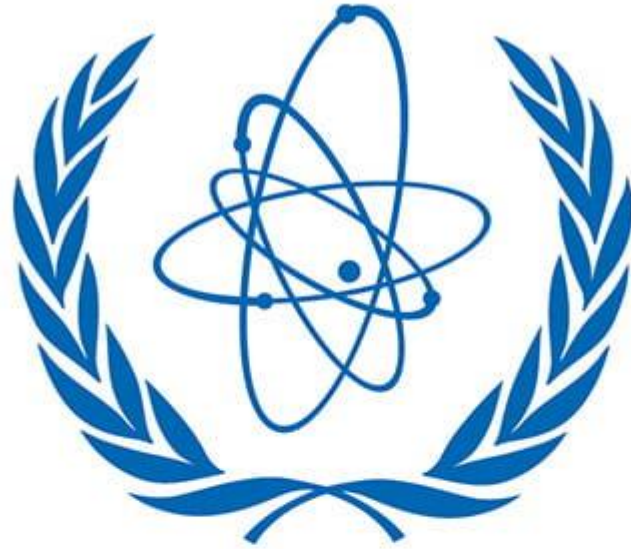

IAEA

International Atomic Energy Agency

Atoms for Peace and Development

Q. The Economic and Social Commission for Asia and Pacific (ESCAP) is located at

- A. Manila
- B. Singapore
- C. Kualalumpur
- D. Bangkok

Q. The Economic and Social Commission for Asia and Pacific (ESCAP) is located at

- A. Manila
- B. Singapore
- C. Kualalumpur
- D. Bangkok**







SSB Interview Online Coaching 2025

SSB Interview: 🎓 Live Classes 🎥 In-Depth Lectures 📖 SSB Notes 🔥 Mock Tests 📅 Current Affairs ✂️ Defence Current Affairs.

★★★★★ 5.0 (253)

Content 18

🔍 FILTER BY TYPE ▾

-  **SSB Live Batch January 2025**
Course • 969 Lessons 11 Trials
-  **SSB Live Batch February 2025 – Enroll Now**
Course • 1 Lessons 1 Trial
-  **Basics of SSB Interview**
Course • 68 Lessons
-  **OIR Test – Verbal Reasoning – Part 1**
Course • 618 Lessons
-  **OIR Test – Verbal Reasoning – Part 2**
Course • 401 Lessons



🕒 365 Days validity

₹ 6,999 ~~₹ 9,999~~ 30% OFF

[BUY BUNDLE](#)

[START A FREE TRIAL](#)

What's included

📁 18 Courses

Other Pricing Plans

Validity 30 Days

30 Days Validity

[Details](#)

₹4,999 ~~₹5,999~~ 17% off

[BUY NOW](#)

AFCAT Exam Online Coaching 2025

AFCAT 2025: Live Classes In-Depth Lectures Study Notes Mock Tests Current Affairs Defence Current Affairs.

★★★★★ 5.0 (147)

Content 22

- Search in bundle FILTER BY TYPE
- 

AFCAT 1 2025 Live Batch - 2
Course • 331 Lessons
 - 

AFCAT 2 2024 Exam Answerkey | 09 - 11 Aug 2024 | Shift 1 & 2
Course • 228 Lessons 1 Trial
 - 

AFCAT 1 2024 Live Batch - 2
Course • 148 Lessons 2 Trials
 - 

AFCAT 1 2024 Live Batch - 1
Course • 315 Lessons 1 Trial
 - 

AFCAT Exam Overview
Course • 26 Lessons



180 Days validity

₹ 4,999 ~~₹ 5,999~~ 17% OFF

BUY BUNDLE

START A FREE TRIAL

What's included

22 Courses

Other Pricing Plans

Validity 12 Months

365 Days Validity

[Details](#)

₹5,999 ~~₹7,999~~ 25% off

BUY NOW

Bundles 13

[View All](#)



Sainik School Exam Course for Class 6

5 Courses

₹ 2,999 ~~₹ 5,999~~ 50% OFF



SSB Interview Online Coaching 2025

18 Courses

₹ 6,999 ~~₹ 9,999~~ 30% OFF

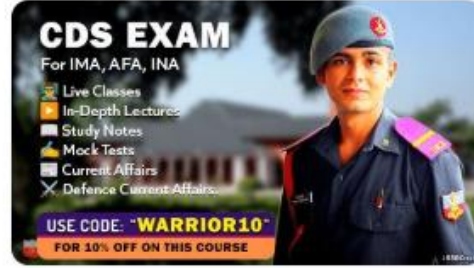

CDS Exam Online Coaching 2025

23 Courses

₹ 4,999 ~~₹ 5,999~~ 17% OFF

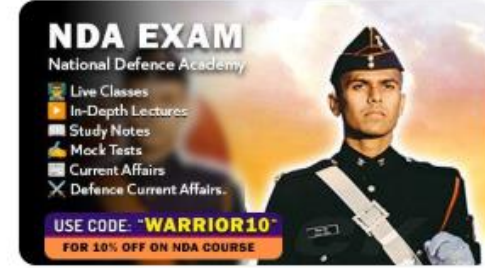

NDA Exam Online Coaching 2025

23 Courses

₹ 4,999 ~~₹ 5,999~~ 17% OFF

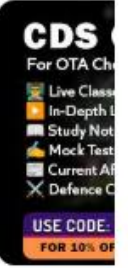

CDS Exam Online Coaching 2025

22 Courses

₹ 4,499

Test series 07

[View All](#)

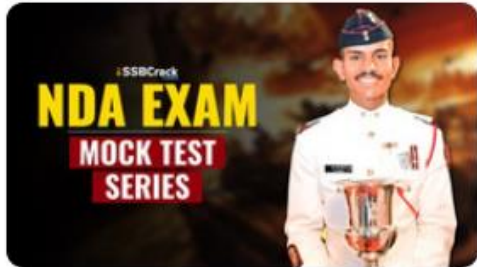

NDA Mock Test Series 2025

40 Tests

₹ 499 ~~₹ 999~~ 50% OFF



AFCAT Mock Test Series 2025

20 Tests

₹ 499 ~~₹ 999~~ 50% OFF



CDS Exam Mock Test Series 2025

30 Tests

₹ 499 ~~₹ 999~~ 50% OFF



CDS OTA Exam Mock Test Series 2025

20 Tests

₹ 499 ~~₹ 999~~ 50% OFF



MNS Mock Test Series 2025

20 Tests

₹ 499

India's Most Popular Portal for Defence Exam Preparation

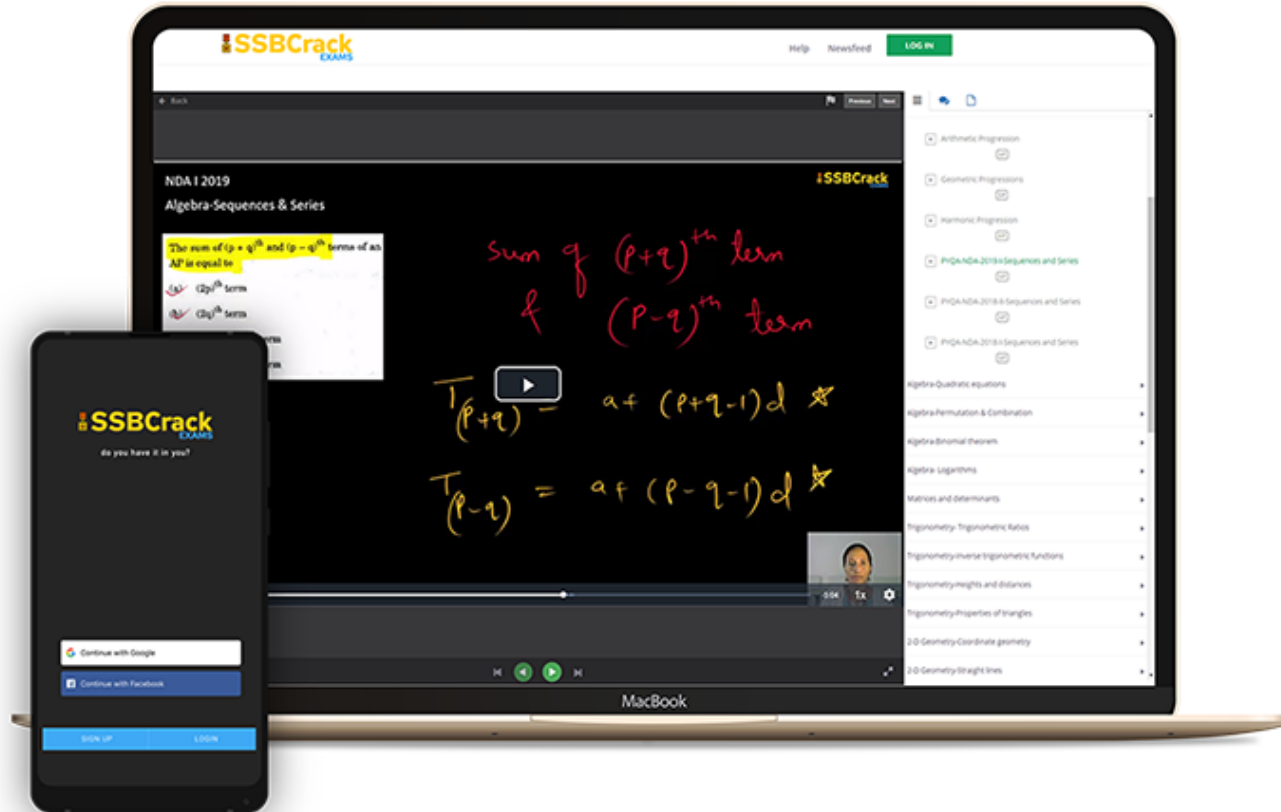
www.ssbcrackexams.com**CODE: WARRIOR10**

get an extra 10% off on all courses

